

Class Note 03: s-Domain Analysis: Example Problems

A. s-domain circuit

Related operation transformations for inductor/capacitor:

$$L\{f'(t)\} = sF(s) - f(0^-) \text{ and } L\left\{\int_0^t f(x)dx\right\} = \frac{F(s)}{s}$$

(ex) From $v = L \frac{di}{dt}$, $V(s) = L\{sI(s) - i(0^-)\} = sLI(s) - Li(0^-)$

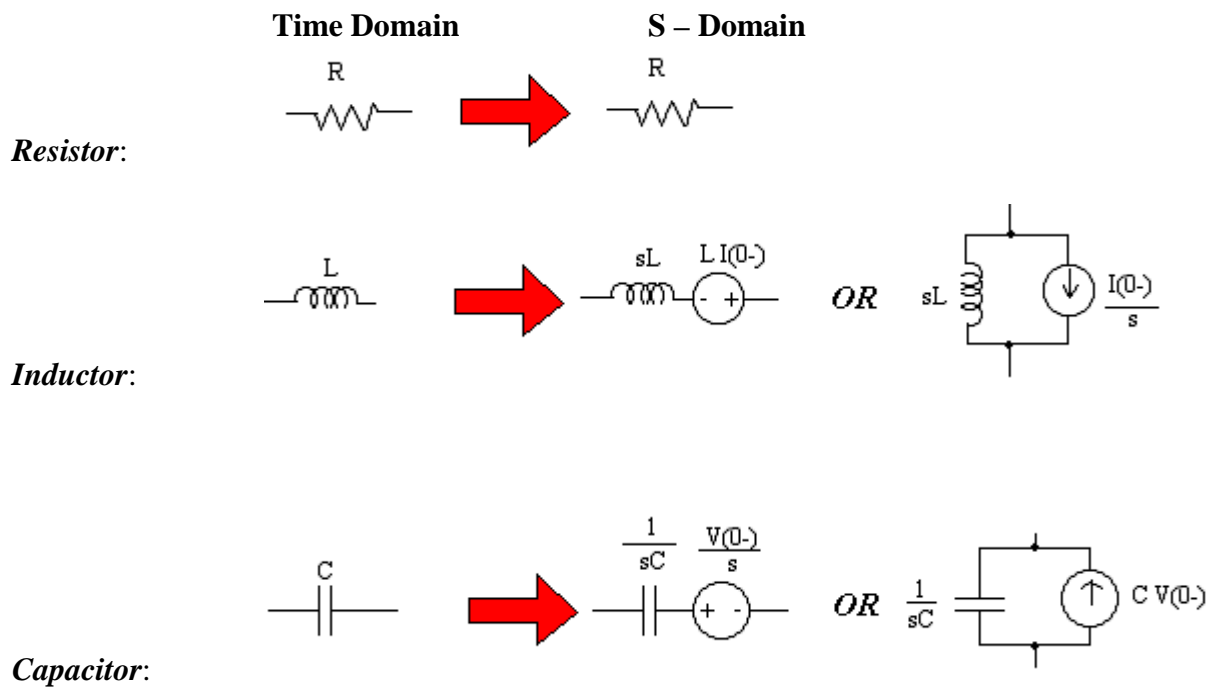

B. EXAMPLE PROBLEMS:

1. The switch in the circuit closed at $t=0$. Find current $i(t)$ at $t>0$ using s-domain analysis

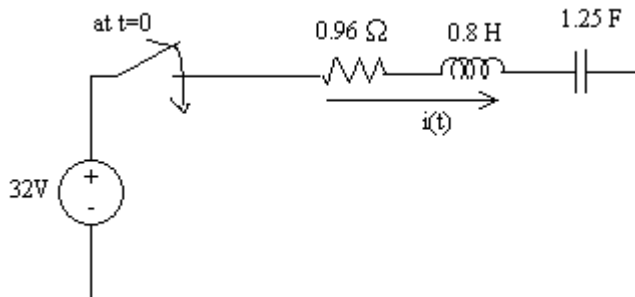

SOLUTION

$t<0$: No initial charge

s-domain circuit:

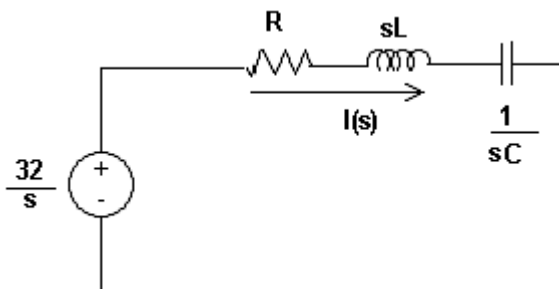

Equation for $I(s)$: $I(s) = \frac{32/s}{R + sL + \frac{1}{sC}}$ with $R=0.96$, $L=0.8$, and $C=1.25$, then

$$I(s) = \frac{32/s}{0.96 + 0.8s + \frac{1}{1.25s}} = \frac{40}{s^2 + 1.25s + 1}$$

Now let's change to an entry form:

$$I(s) = \frac{40}{s^2 + 1.2s + 1} = \frac{40}{(s + 0.6)^2 + 0.8^2} = \frac{50 \cdot (0.8)}{(s + 0.6)^2 + 0.8^2}$$

$i(t)$: $i(t) = 50e^{-0.6t} \sin 0.8t, t>0$

2. The switch in the circuit has been opened for a long time. At $t = 0$ the switch closes. Find voltage $v(t)$ by using s-domain analysis.

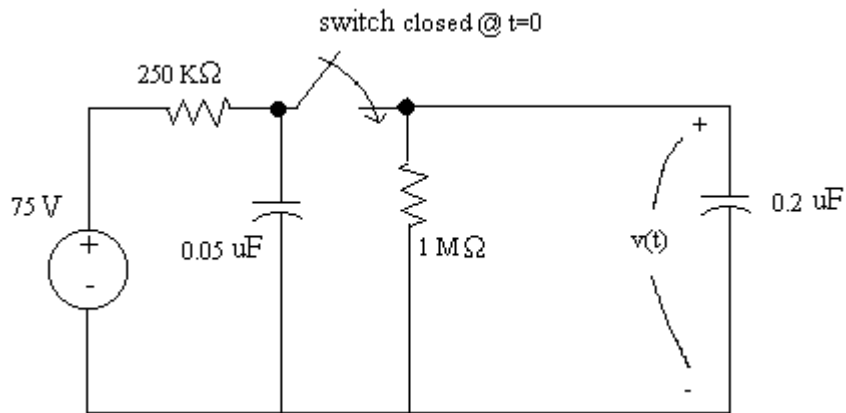

SOLUTION

(a) $t < 0$: Initial voltage across the capacitor C1 is, then, 75 [V]. $V_0 = 75$.

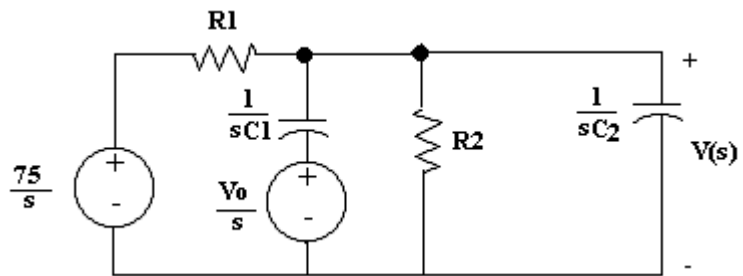
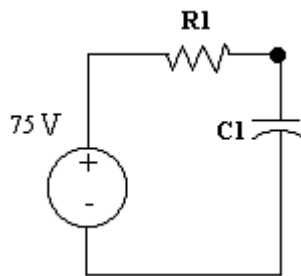

(b) $t > 0$: s-domain circuit: (See above right)

ANSWER: $v(t) = 60u(t) - 45e^{-20t}$, $t > 0$

3. The switch in the circuit shown below has been closed for a long time. At $t=0$, the switch is opened. Find $v(t)$ by inverse Laplace transformation of $V(s)$.

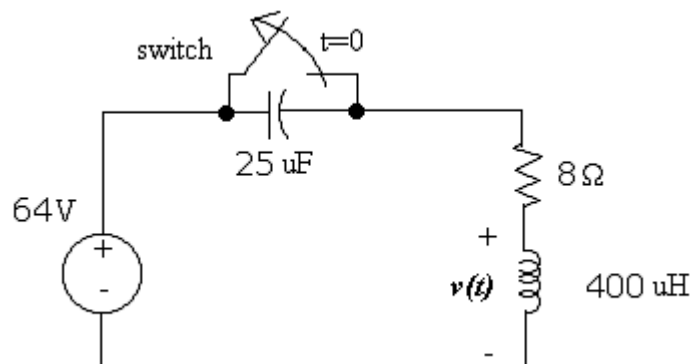

SOLUTION:

ANSWER: $v(t) = -32 \times 10^4 \cdot t \cdot e^{-10^4 t}, t > 0$

4. The switch below has been closed for a long time. At $t = 0$ the switch opens. Find $i(t)$ by inverse Laplace transformation of $I(s)$.

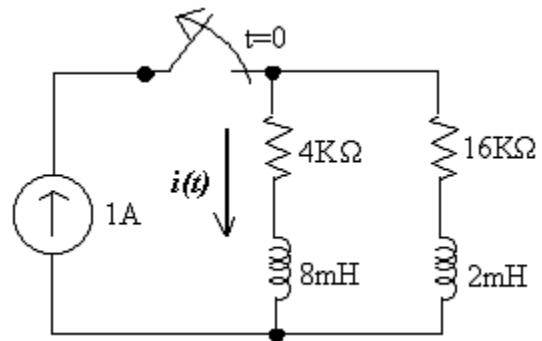

SOLUTION:

ANSWER $i(t) = 0.6e^{-2 \times 10^{-6}t}$, $t > 0$

5. The switch in the circuit seen in the figure below has been in position 1 for a long time. At $t = 0$ it moves instantaneously from 1 to 2 position. Find $v(t)$ by inverse transformation of s-domain voltage $V(s)$

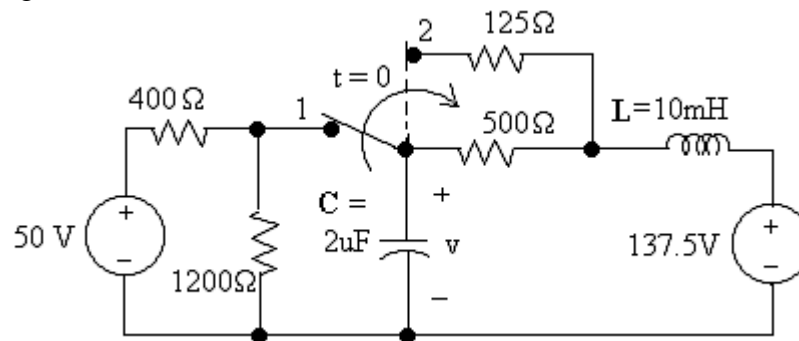

SOLUTION

ANSWER

$$\begin{aligned}
 v(t) &= 137.5u(t) - 62.5e^{-5000t} \cos 5000t - 50e^{-5000t} \sin 5000t \\
 &= 137.5u(t) - \sqrt{62.5^2 + 50^2} e^{-5000t} \cos\left(5000t - \arctan \frac{50}{62.5}\right) \\
 &= 137.5u(t) - 80e^{-5000t} \cos(5000t - 38^\circ)
 \end{aligned}$$

for $t > 0$