

Class Note 19: Operational Amplifier (OP Amp)

**CHAPTER 5. The Operational Amplifier<sup>1</sup>**

**A. INTRODUCTION**

1. The *operational amplifier* or *op amp* for short, is a versatile circuit building block.
2. The *op amp* is an electronic unit that behaves like a voltage-controlled voltage source.
3. The *op amp* may also be regarded as a voltage amplifier with very high gain.
4. An op amp can sum signals, amplify a signal, integrate it, or differentiate it. The ability of the op amp to perform these mathematical operations is the main reason it is called an operational amplifier.
5. The term *operational amplifier* was introduced by John Regazzini and his colleagues, in their work on analog computers for the National Defense Research Council during World War II. The first op amps used vacuum tubes rather transistors.

**B. OP AMP PACKAGE**

1. The op amp is an electronic device consisting of a complex arrangement of resistors, transistors, capacitors, and diodes.
2. Op amps are commercially available in integrated circuit (IC) packages in several forms. A typical one is the 8-pin single or dual in-line package (DIP) shown below.

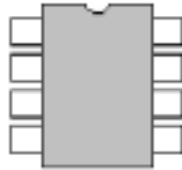

3. For a single DIP op amp (typically **uA741**), pin or terminal 8 is unused (NC), and terminals 1 and 5 are of little concern to us.

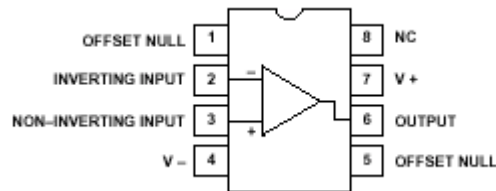

4. For a dual DIP op amp (typically **LM348**), all 8 pins are used for two op amps [left]. A typical quad op amp (LM324) is displayed below right.



<sup>1</sup> The main goal of this chapter is to get student to be familiar with the node voltage method application when active elements are present in a circuit.

### C. CIRCUIT SYMBOLS AND TERMINAL BEHAVIORS

- The five important terminals in an op amp are:
  - Inverting input (-)
  - Noninverting input (+)
  - Output
  - Positive power supply,  $V_+$
  - Negative power supply,  $V_-$
- The circuit symbol for the op amp is the triangle.
- An input applied to the noninverting terminal appears with the same polarity at the output.
- An input applied to the inverting terminal appears inverted at the output.
- The op amp must be powered by a voltage supply.

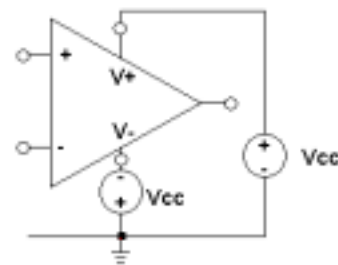
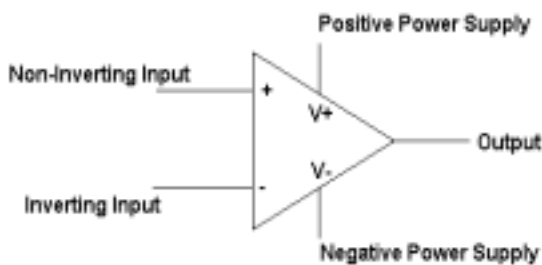

- The equivalent circuit model of an op amp is shown below. The output section consists of a voltage-controlled dependent voltage source in series with the output resistance  $R_o$ . The output resistance  $R_o$  is the Thevenin equivalent resistance seen at the output terminal. The input resistance  $R_i$  is the Thevenin equivalent resistance seen at the input terminals.

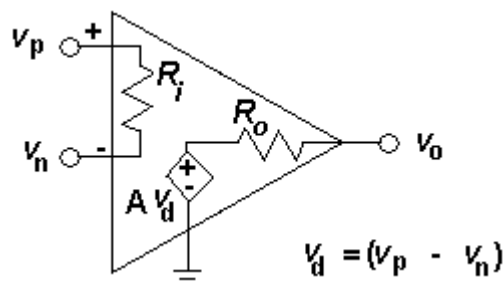

- Therefore, according to above equivalent circuit of op amp, it can be said that the op amp senses the difference between the two inputs, multiplies it by the gain  $A$ , and causes the resulting voltage to appear at the output.
- The output voltage of the equivalent circuit then is given by,  $v_o = A(v_p - v_n)$  where  $v_p$  is the voltage between the non inverting terminal and ground, and  $v_n$  is the voltage between the inverting terminals and ground.  $A$  is called the open-loop voltage gain since it is the gain of the op amp without any external feedback from output to input.
- Typical values of voltage gain  $A$ , input resistance, output resistance, and supply voltage:

Parameters	Typical Range	Ideal Values
Open-loop gain, $A$	$10^5 - 10^8$	$\infty$
Input Resistance, $R_i$	$10^6 - 10^{13} \Omega$	$\infty \Omega$
Output Resistance, $R_o$	$10 - 100 \Omega$	$0 \Omega$
Supply Voltage, $V_{cc}$	$5 - 24 \text{ V}$	

9. Output voltage limitation: The magnitude of the output voltage cannot exceed  $|V_{cc}|$ .

Depending on the power supply voltage and the differential input voltage  $v_d=v_p-v_n$ , op amp can operate in three modes:

- (a) Positive saturation:  $v_o = V_{cc}$
- (b) Linear region:  $-V_{cc} \leq v_o \leq V_{cc}$
- (c) Negative saturation:  $v_o = -V_{cc}$

10. The voltage transfer characteristics combine the three regions of mode.

$$v_o = \begin{cases} -V_{cc} & \text{if } A(v_p - v_n) < -V_{cc} \\ A(v_p - v_n) & \text{if } -V_{cc} \leq A(v_p - v_n) \leq +V_{cc} \\ +V_{cc} & \text{if } A(v_p - v_n) > +V_{cc} \end{cases}$$

#### D. IDEAL OP AMP MODEL

1. An op amp is ideal if it has the following characteristics:

- (a) Infinite open-loop gain, i.e.,  $A = \infty$
- (b) Infinite input resistance, i.e.,  $R_i = \infty \Omega$
- (c) Zero output resistance, i.e.,  $R_o = 0 \Omega$

2. Two important characteristics of the ideal op amp for circuit analysis:

- (a) The current into both input terminals are zero, i.e.,  $i_p = i_n = 0$ . This is due to infinite input resistance: an open circuit exists between two terminals and current cannot flow through.
- (b) The voltage across the input terminals is negligibly small, i.e.,  $v_p = v_n$ . This is due to infinite open-loop gain. In the linear region, the magnitude of the output voltage must be less than the supply power voltage, i.e.,  $-V_{cc} \leq A(v_p - v_n) \leq V_{cc}$ . Even for a practical op amp, the gain  $A$  is about the  $10^5$ , and the  $V_{cc}$  is just about 24V. Therefore, to satisfy the

inequality for the linear region mode,  $(v_p - v_n) \leq \frac{24}{10^5} = 0.24 \times 10^{-3} = 0.24 \text{ [mV]}$ .

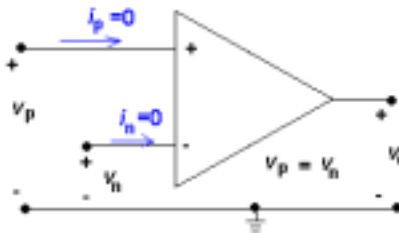

### E. EXAMPLE of OP AMP CIRCUIT ANALYSIS

(using the ideal op amp model and the non-ideal op amp equivalent circuit model)

Q: Calculate the closed-loop gain (i.e., there is a feedback)  $\frac{v_o}{v_s}$ , and find  $i_o$  when  $v_s = 1$  [V].

(with  $R_i=2M\Omega$ ,  $R_o=50 \Omega$ , and open-loop gain  $A=2 \times 10^5$ .)

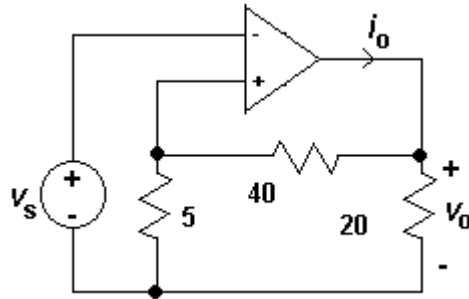

### F. ANALYSIS A: using the exact (i.e., non-ideal) OP Amp model

(a) The circuit diagram and its redrawn circuit are shown below:

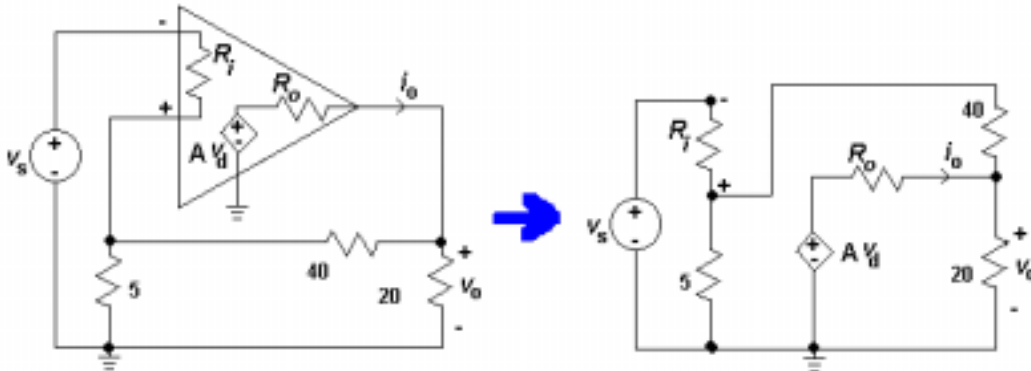

(b) Let's apply the node-voltage method to the right circuit.

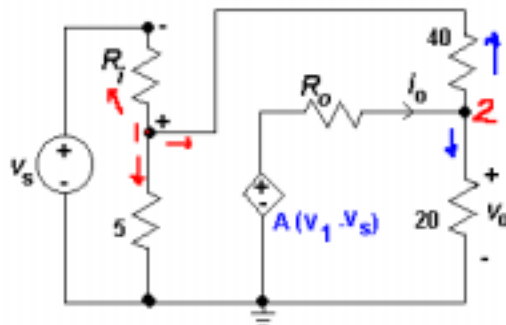

(c) @ node 1:  $\frac{V_1 - V_s}{R_i} + \frac{V_1}{5} + \frac{V_1 - V_o}{40} = 0$  (Since  $V_o = V_2$ ). with  $V_s = 1$

$$\implies \frac{V_1 - 1}{2 \times 10^6} + \frac{V_1}{5} + \frac{V_1 - V_o}{40} = 0 \implies (V_1 - 1) + 0.4 \times 10^5 V_1 + 0.05 \times 10^6 (V_1 - V_o) = 0$$

$$\text{---> } (1+0.4 \times 10^5 + 0.05 \times 10^6)V_1 - 0.05 \times 10^6 V_0 = 1 \text{ -----(1)}$$

$$\text{(d) @ node 2: } \frac{V_o - V_1}{40} + \frac{V_2}{20} + \frac{V_0 - A(V_1 - V_s)}{R_o} = \frac{V_o - V_1}{40} + \frac{V_2}{20} + \frac{V_0 - A(V_1 - V_s)}{50} = 0$$

$$\text{It simplifies to: } 5V_0 - 5V_1 + 10V_2 + 4V_0 - 4AV_1 + 4AV_s = 0$$

$$\text{Again, } 19V_0 - V_1(5 + 4A) + 4AV_s = 0 \Rightarrow 19V_0 - (5 + 8 \times 10^5)V_1 + 8 \times 10^5 = 0$$

$$\text{---> } -800005V_1 + 19V_0 = -800000 \text{ -----(2)}$$

$$\text{From (1): } V_0 = \frac{450001V_1 - 1}{50000}$$

$$\text{By substitution to (2): } V_1 = 0.9999 \text{ and } V_0 = 8.999$$

$$\text{Therefore, } \frac{V_0}{V_s} = 8.999$$

(e) For the current  $i_o$ : applying KCL at node 2 yields:

$$i_o = \frac{V_o - V_1}{40} + \frac{V_o}{20} = \frac{3V_o - V_1}{40} = \frac{26.997 - 0.999}{40} = 0.649 \text{ [A]}$$

## F. ANALYSIS A: using the Ideal OP Amp model

(a) By the constraints of ideal op amp,  $v_p = v_n$  and  $i_p = i_n = 0$ , and node voltage method application:

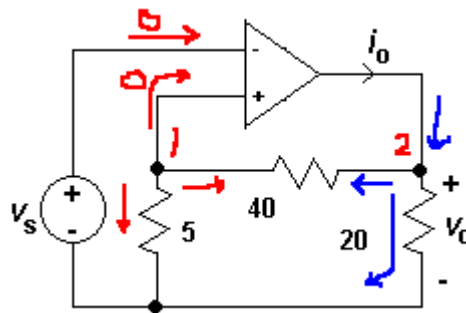

(b) Constraints and hidden values: by the ideal op amp model,  $V_1 = V_s$  and  $V_o = V_2$ .

$$\text{(c) @ node 1: } 0 + \frac{V_1 - V_o}{40} + \frac{V_1}{5} = 0 \text{ ---> } V_o = 9V_1 = 9V_s$$

Therefore the closed-loop gain is:  $\frac{v_o}{v_s} = 9$

$$\text{(d) @ node 2: } i_o = \frac{V_o - V_1}{40} + \frac{V_o}{20} = \frac{2V_o - V_s}{40} \text{ --- (with } V_s = 1)$$

$$\text{---> } i_o = \frac{3(9V_s) - V_s}{40} = \frac{26}{40} = 0.65 \text{ [A]}$$