

Class note 13: Maximum Power Transfer

A. Maximum Power Transfer

1. In many practical situations, a circuit is designed to provide power to a load.
2. Thevenin theorem is useful in finding the maximum power a linear circuit can deliver to a load. Therefore, usually, a maximum power transfer problem is another form of Thevenin equivalent circuit derivation problem.
3. Maximum Power Transfer Theorem: If the entire circuit is replaced by its Thevenin equivalent circuit, except the load, as shown below, the power absorbed by the load is:

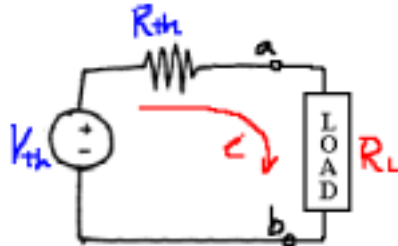

$$P_L = i^2 R_L = \left(\frac{V_{th}}{R_{th} + R_L} \right)^2 \cdot R_L = \frac{V_{th}^2 R_L}{[R_{th} + R_L]^2}$$

Since, for a given circuit, V_{th} and R_{th} are fixed, the load power is a function of the load resistance R_L . By differentiating P_L with respect to R_L and set the result equal to zero, we have the following maximum power transfer theorem: **maximum power occurs when R_L is equal to R_{th} .**

4. When maximum power transfer condition is met, i.e. $R_L=R_{th}$, the maximum power transferred is:

$$P_L = \frac{V_{th}^2 R_L}{[R_{th} + R_L]^2} = \frac{V_{th}^2 R_{th}}{[R_{th} + R_{th}]^2} = \frac{V_{th}^2}{4R_{th}}$$

5. Thus, we are pretty much sure that, when we are told to use an 8Ω speaker (if you look at the back of the speaker cone, you can find the resistance value marking) not 16Ω one, the internal amplifier resistor is close to 8Ω . As shown below, with maximum amplifier voltage $40V$, the output power is maximized when the speaker (i.e., load) resistance is same as the internal amplifier resistance.

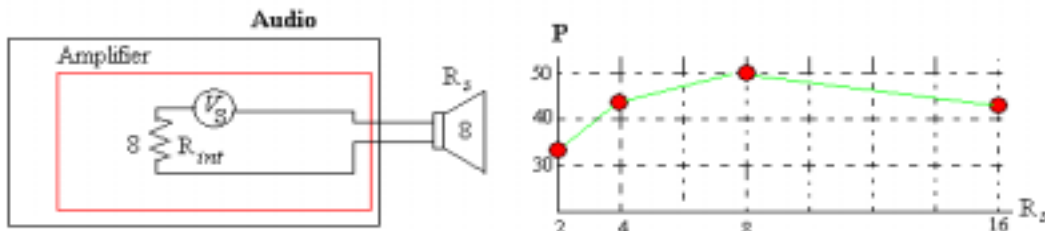

6. An example problem:

Find the load resistance R_L that enables the circuit (left of the terminals a and b) to deliver maximum power to the load. Find also the maximum power delivered to the load.

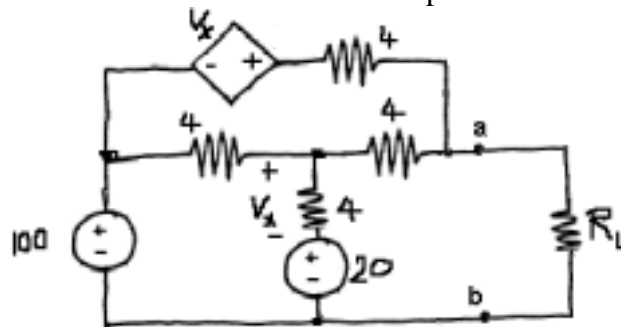

Solution:

We have to find the Thevenin equivalent circuit to apply the maximum power transfer theorem.

(a) V_{th} derivation of the circuit: open-circuit voltage

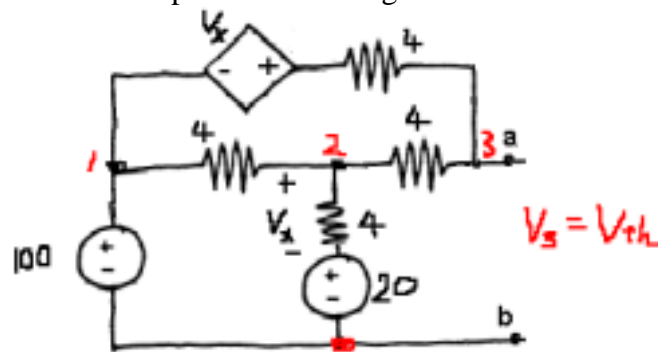

Constraints: $V_1=100$, $V_2 - 20=V_x$, and $V_3=V_{th}$

@ node 2: $\frac{V_2 - 100}{4} + \frac{V_2 - 20}{4} + \frac{V_2 - V_{th}}{4} = 0 \rightarrow 3V_2 - V_{th} = 120$ (1)

@ node 3: $\frac{V_{th} - V_2}{4} + \frac{V_{th} - (V_2 - 20) - 100}{4} = 0 \rightarrow -2V_2 + 2V_{th} = 80$ (2)

(1)*2 + (2)*3 $\rightarrow V_{th}=120$ [V]

(b) R_{th} derivation (by Test Voltage Method): After deactivation & test voltage application, we have:

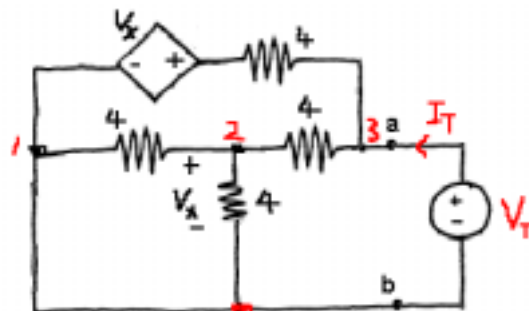

Constraints: $V_3=V_T$ and $V_2=V_x$

@ node 2: $\frac{V_2}{4} + \frac{V_2}{4} + \frac{V_2 - V_T}{4} = 0 \rightarrow 3V_2 - V_T = 0$ (1)

@ node 3 (KCL): $\frac{V_T - V_2}{4} + \frac{V_T - V_2}{4} - I_T = 0 \rightarrow V_T - V_2 = 2I_T$ (2)

From (1) and (2): $\frac{V_T}{I_T} = 3 = R_{th}$

(c) Maximum Power Transfer: now the circuit is reduced to:

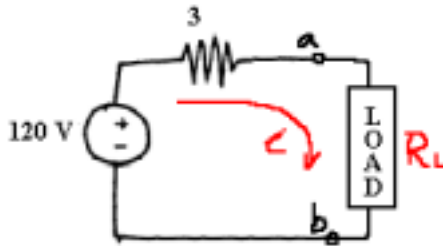

To obtain maximum power transfer, then, $R_L=3=R_{th}$.

Finally, maximum power transferred to R_L is: $i^2 R_L = \left(\frac{120}{6}\right)^2 \cdot 3 = 1200$ [W]

7. Another example

Determine the maximum power that can be delivered to the variable resistor R.

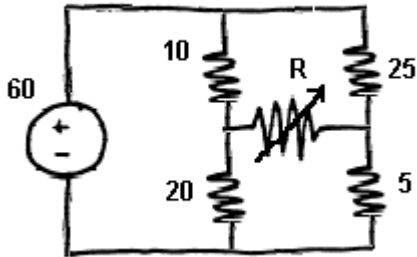

SOLUTION:

(a) V_{th} : Open circuit voltage

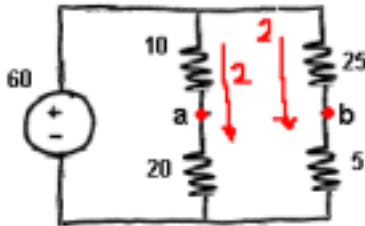

From the circuit, $V_{ab}=V_{th}=40-10=30$ [V]

(b) R_{th} : Let's apply Input Resistance Method:

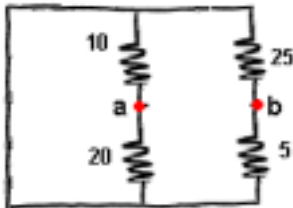

Then $R_{ab} = (10//20) + (25//5) = 6.67+4.16=10.83 = R_{th}$.

(c) Thevenin circuit:

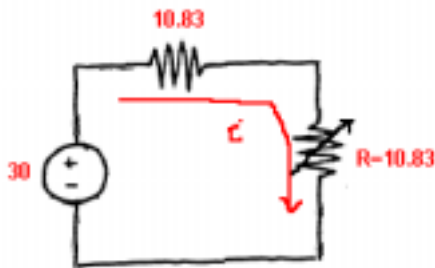

$$P_{max} = \left(\frac{30}{2 \times 10.83} \right)^2 \cdot (10.83) = 20.77 \text{ [W]}$$

8. Another example:

Find the value of load R in the network that will achieve maximum power transfer and determine the values of the maximum power.

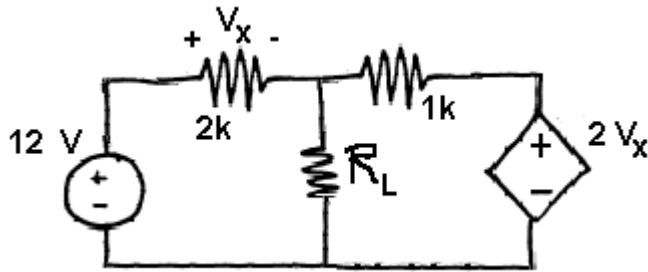

SOLUTION:

a. Let's find the Thevenin circuit with respect to the terminals where the load is attached.

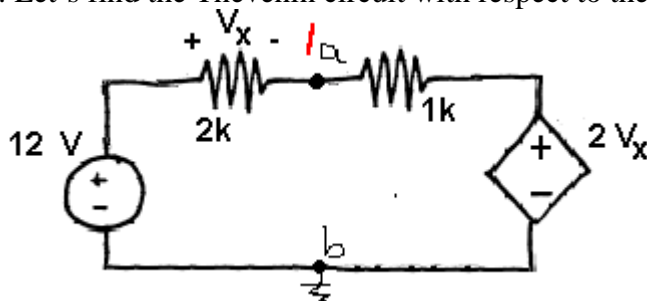

Hidden values: By KVL at left: $-12 + V_x + V_1 = 0 \rightarrow V_x = 12 - V_1$

For V_{th} :

$$\text{@ 1: } \frac{V_1 - 12}{2000} + \frac{V_1 - 2V_x}{1000} = 0 \rightarrow \frac{V_1 - 12}{2000} + \frac{V_1 - 2[12 - V_1]}{1000} = 0 \rightarrow V_1 = V_{th} = \frac{60}{7} \text{ [V]}$$

For R_{th} :

(a) By short circuit current method:

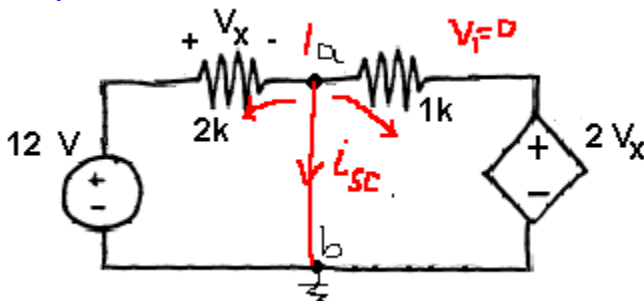

Now $V_x = 12$.

$$\text{@ 1: } \frac{0 - 12}{2000} + i_{sc} + \frac{0 - 2(12)}{1000} = 0 \rightarrow i_{sc} = \frac{60}{2000}$$

Therefore: $R_{th} = \frac{V_{th}}{i_{sc}} = \frac{60/7}{60/2000} = \frac{2000}{7}$

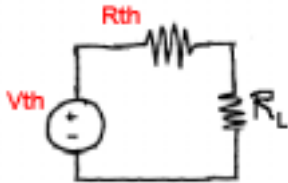

(b) By Test Voltage method:

Applying a test voltage after deactivation of the independent voltage source, we have:

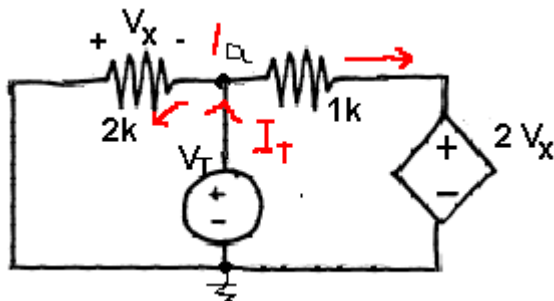

Hidden values: $V_x = -V_T$ and $V_1 = V_T$.

Applying KCL at node 1: $I_T = \frac{V_T}{2000} + \frac{V_T - 2(-V_T)}{1000} = \frac{7V_T}{2000} \rightarrow R_{th} = \frac{V_T}{I_T} = \frac{2000}{7}$

9. One last example (a problem in EXAM#2 of Spring 2002)

Q: Determine the value of the resistor so that the maximum power can be delivered to it?

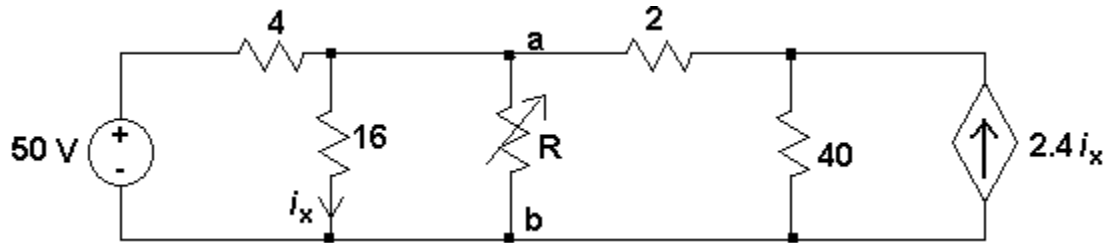

SOLUTION: