

Class Note 5: Resistor

I. Equivalent Resistance---Example

Problem Setting:

Find the total equivalent resistance at the terminals a and b: R_{ab}

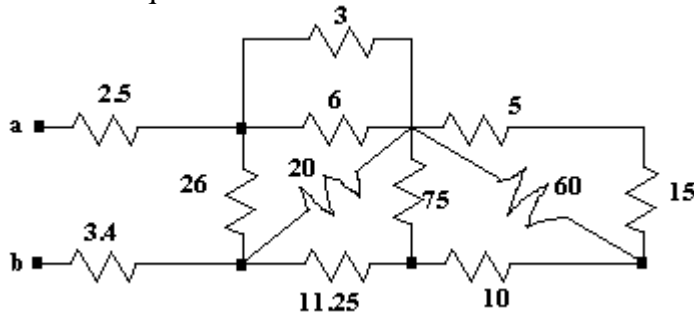

Step 1. Marking nodes always helps. And we attack it from the right flank.

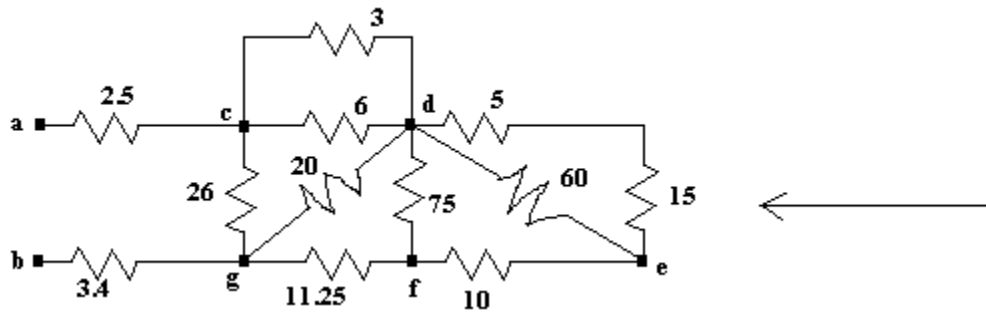

Step 2. Now follow the figures and find the unmarked resistances.

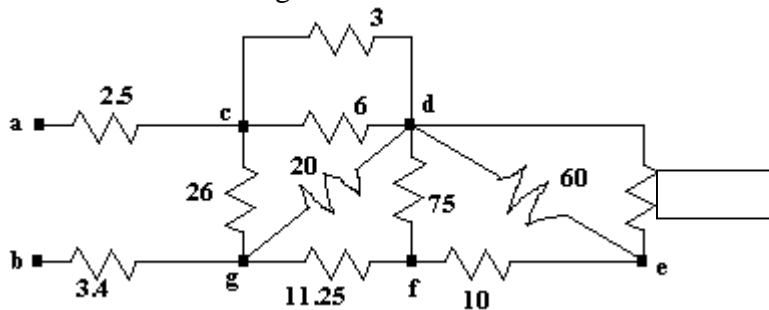

Step 3.

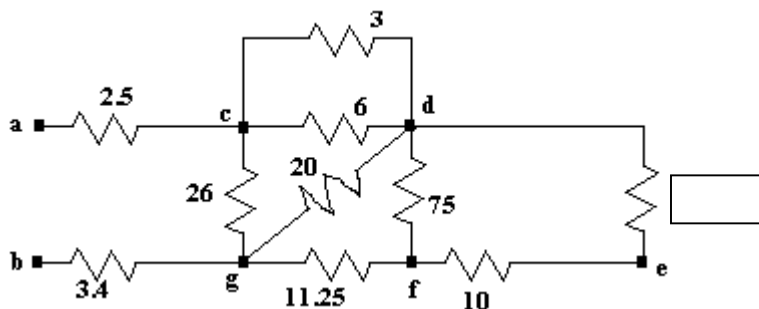

Step 4.

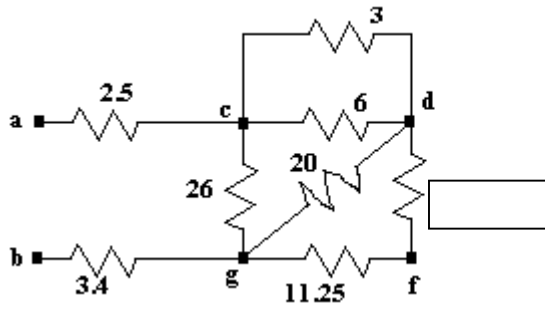

Step 5.

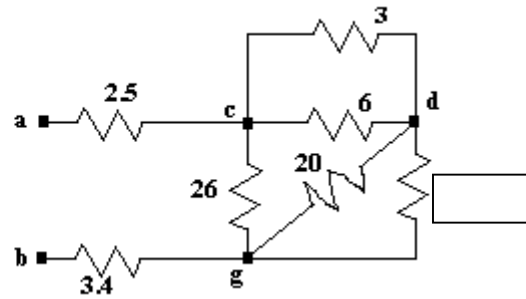

Step 6.

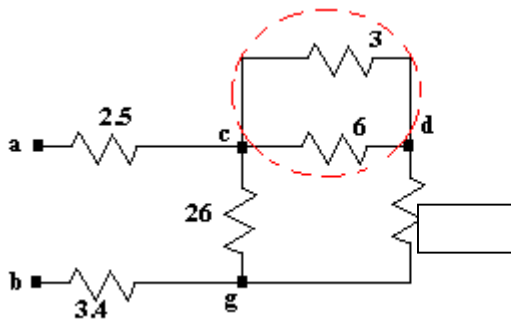

Step 7.

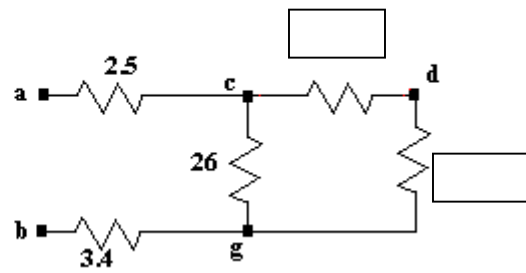

Step 8.

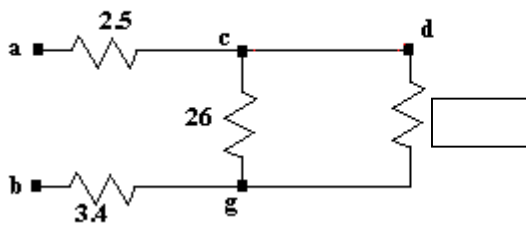

Step 9

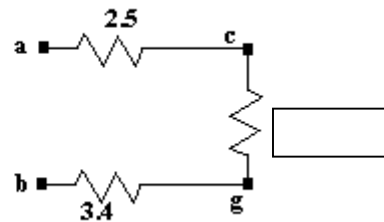

Step 10. Finally, $R_{ab} =$

II. Resistor Specifications

1. There are three important parameters that specify a resistor: value, tolerance, and power rating.
2. The tolerance specifications are typically 5% and 10%.
3. The following are a part of standard resistor values for 5% and 10 % tolerance:

Tolerance	Standard Resistor Values [Ω]
5%	1.0, 1.1, 1.2, 1.3, 1.5, 1.6, 1.8, 2.0, 2.2, 2.4, 2.7, 3.0, 3.3, 3.6, 3.9, 4.3, 4.7, 5.1, 5.6, 6.2, 6.8, 7.5, 8.2, 9.1, 10, 11, 12, 13, 15, 16, 18, 20, 22, 24, 27, 30, 33, 36, 39, 43, 47, 51, 56, 62, 68, 75, 82, 91, 100, 110, 120, 130, 150, 160, 180, 200, 220, 240, 270, 300, 330, 360, 390, 430, 470, 510, 560, 620, 680, 750, 820, 910, 1.0k, 1.1k, 1.2k, 1.3k, 1.5k, 1.6k, 1.8k, 2.0k, 2.2k, 2.4k, 2.7k, 3.0k, 3.3k, 3.6k, 3.9k, 4.3k, 4.7k, 5.1k, 5.6k, 6.2k, 6.8k, 7.5k, 8.2k, 9.1k, 10k, 11k, 12k, 13k, 15k, 16k, 18k, 20k, 22k, 24k, 27k, 30k, 33k, 36k, 39k, 43k, 47k, 51k, 56k, 62k, 68k, 75k, 82k, 91k
10%	1.2, 1.5, 1.8, 2.2, 2.7, 3.3, 3.9, 4.7, 5.6, 6.8, 12, 15, 18, 22, 27, 33, 39, 47, 56, 68, 82, 120, 150, 180, 220, 270, 330, 390, 470, 560, 680, 820, 1.2k, 1.5k, 1.8k, 2.2k, 2.7k, 3.3k, 3.9k, 4.7k, 5.6k, 6.8k, 8.2k, 12k, 15k, 18k, 22k, 27k, 33k, 39k, 47k, 56k, 68k, 82k

Now you are wondering what kind of "standard" resistor values looks like one above. Here is some answer:

The Electronic Industries Association (EIA) specifies "standard values" for resistors, sometimes referred to as the "preferred value" system. The preferred value system has its origins in the early years of the last century at a time when most resistors were carbon-graphite with relatively poor manufacturing tolerances. The rationale is simple - select values for components based on the tolerances with which they could be manufactured. Using 10% tolerance devices as an example, suppose that the first preferred value is 100 ohms. It makes little sense to produce a 105 ohm resistor since 105 ohms falls within the 10% tolerance range of the 100 ohm resistor. The next *reasonable* value is 120 ohms because the 100 ohm resistor with a 10% tolerance is expected to have a value somewhere between 90 and 110 ohms. The 120 ohm resistor has a value ranging between 110 and 130 ohms. Following this logic, the preferred values for 10% tolerance resistors between 100 and 1,000 ohms would be 100, 120, 150, 180, 220, 270, 330 and so on (rounded appropriately).

4. E series: EIA has 6 series of resistor values with different tolerances.

The E6 series (6 values for each multiple of ten, for resistors with 20% tolerance)

10, 15, 22, 33, 47, 68, ... then it continues 100, 150, 220, 330, 470, 680, 1000 etc.

Notice how the step size increases as the value increases. For this series the step (to the next value) is roughly half the value.

The E12 series (12 values for each multiple of ten, for resistors with 10% tolerance)

10, 12, 15, 18, 22, 27, 33, 39, 47, 56, 68, 82, ... then it continues 100, 120, 150 etc.

5. The power rating specifies the maximum power that can be dissipated by the resistor.

Electrical energy is converted to heat when current flows through a resistor. Usually the effect is negligible, but if the resistance is low (or the voltage across the resistor high) a large current may pass making the resistor become noticeably warm. The resistor must be able to withstand the heating effect and resistors have power ratings. Some typical ratings are 1/8 W, 1/4 W, 1/2 W, 1W, and 2W. Power ratings of resistors are rarely quoted in parts lists because for most circuits the standard power ratings of 1/4 W or 1/2 W are suitable. For the rare cases where a higher power is required it should be clearly specified in the parts list, these will be circuits using low value resistors (less than about 300Ω) or high voltages (more than 15V). In selecting a resistor for some particular application, one important criterion is the expected power dissipation.

6. Example Problem 1

From the circuit given below, we want to find the range for the current and power dissipation in the resistor if R is a 270Ω resistor with a tolerance of 10%.

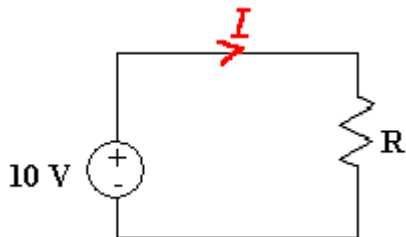

SOLUTION:

R's value range: $270 \pm 10\%$ ---> 270 ± 27 ---> [243, 297] or $R_{\min} = 243$ and $R_{\max} = 297$

Using Ohm's Law: $I = V / R = 10 / R$

$$I_{\max} = \frac{10}{R_{\min}} = \frac{10}{243} = 0.0412 \text{ [A]}$$

$$I_{\min} = \frac{10}{R_{\max}} = \frac{10}{297} = 0.0337 \text{ [A]}$$

$$\text{From } P = VI = \frac{V^2}{R}: \quad P_{\max} = \frac{V^2}{R_{\min}} = \frac{100}{243} = 0.412 \text{ [W]} \quad P_{\min} = \frac{V^2}{R_{\max}} = \frac{100}{297} = 0.337 \text{ [W]}$$

So we know that the proper power rating of the resistor is 1/2 W.

7. Example Problem 2

From the circuit shown below;

- Find the required value for the resistor R ,
- Use the Standard Resistor Value table to select a standard 10% tolerance resistor for R ,
- Using the resistor selected in (b), determine the voltage across the 390Ω resistor, and
- Determine the power rating for the selected standard resistor R .

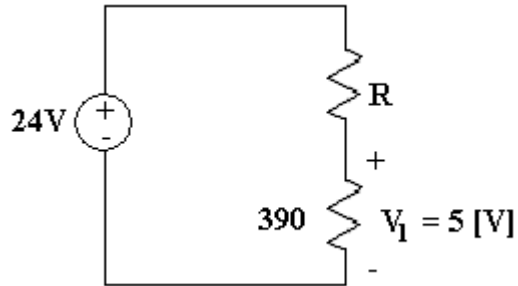

SOLUTION: