

Class Note 4: Polarity Revisited

If you are still confused with polarity stuff, especially, when you apply KVL around a loop, this note could be the one you need now.

Passive Element:

Think about a resistor in a circuit.



And we know that there must be a “current through” and a “voltage across” the resistor. Let’s assume current flows from left to right [Below left]. This current flow implies that the left side of the resistor has higher potential than the right side, by the Positive Convention. So the polarity of the voltage across gets (+) at left and (-) at right [Below right].



On the other hand, if you assume voltage polarity first [Below left], this implies that you also assume that the current flows from left to right [Below right].

**Voltage Source:**

First remember that a voltage source already has its polarity. So there is no way to mark additional polarity. The only freedom you have is to assume a current flow.

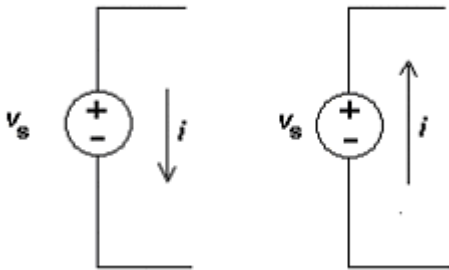

Current Source:

As in the voltage source case, a current source already has a current flow. Therefore, you can only assume a voltage polarity of your choice.

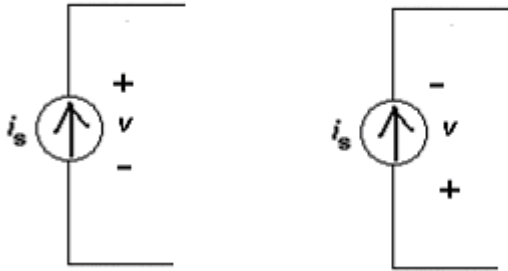

KVL and Polarity:

1. Remember that KVL is about V (“voltage”) around a loop.
2. Therefore, current flow is ignored (or indirectly involved through Ohm’s Law, $V=I \cdot R$)
3. Each element (active or passive) must have voltage polarity marks. It’s about voltage!
4. To apply KVL, we have to assume a direction (clockwise(CW) or counter-clockwise (CCW)) to check the polarity marks of each every element. This is only to determine the sign (+ or -) of a voltage in a loop. Under a given “direction of look,” if a polarity changes (+) to (-), then the sign for the voltage is (+). If it changes (-) to (+), then the sign should be (-).
5. **Example:** Find the current I_9

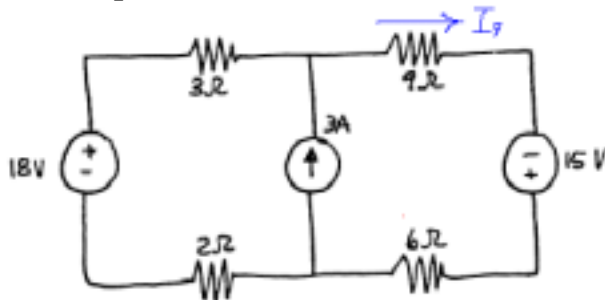

Solution:

(1) Since the current flow is give at the right branch, we mark voltage polarity by the positive convention.

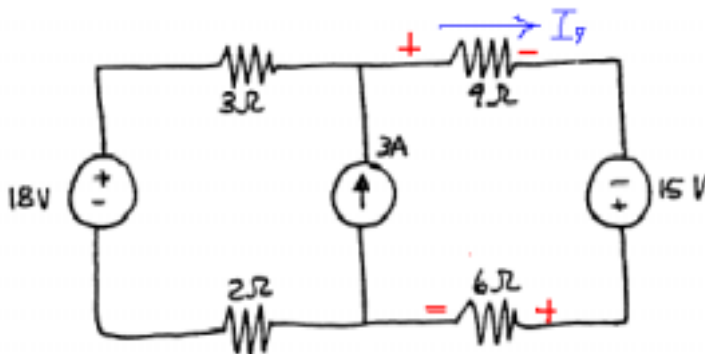

(2) Let's mark nodes (a and b) and the current of the left branch. You can assume the current flow. Here I assumed that the current of the left branch flows to the node a. Then the voltage polarity marks should follow the positive convention.

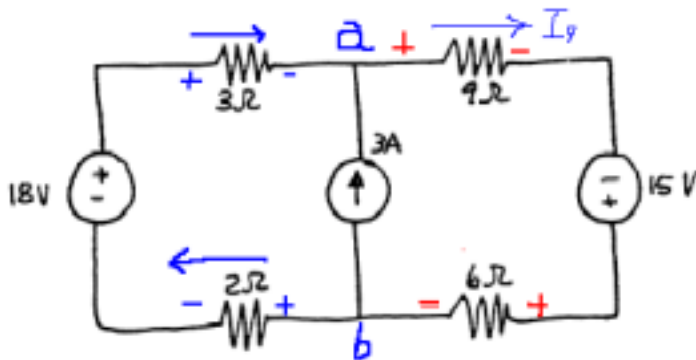

(3) Now there is one element left without polarity mark: the current source. So we choose the voltage polarity of it: (+) top and (-) bottom.

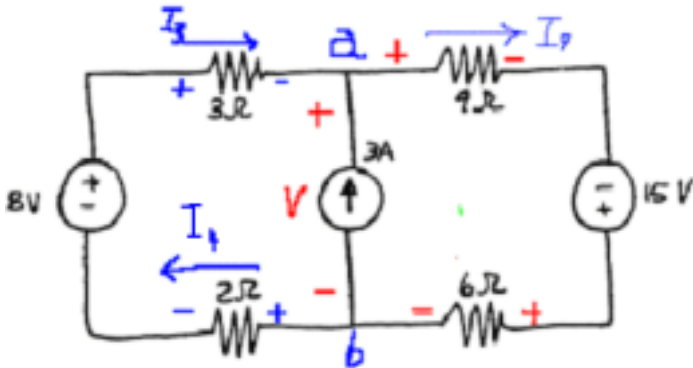

(4) Let's apply KCL (CURRENT ONLY) at the node a: $I_3 + 3 = I_9$ ----> $I_3 = I_9 - 3$ (1)

(5) To find I_3 , we apply KVL at the left loop. The "look" direction is chosen as CW. **Then, do not look at the current direction; look only the voltage polarity.** KVL is about voltage.

Now we have a KVL equation as below:

$$-18 + (3)(I_3) + V + (2)(I_4) = 0 \quad \& \quad I_4 = I_3 \quad \text{---->} \quad 3I_3 + 2I_9 + V = 24 \quad (2)$$

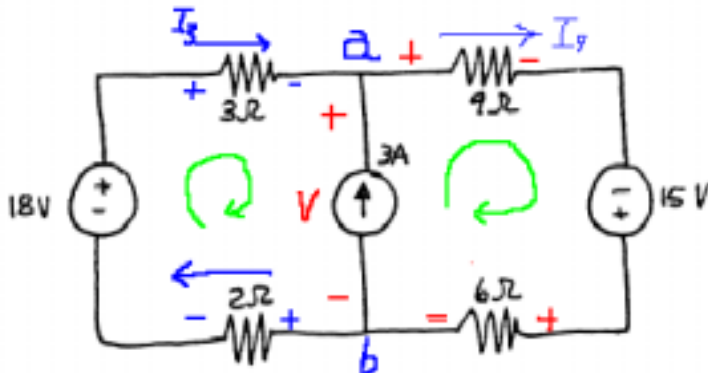

(6) From the right loop with the same CW look direction:

$$-V+9(I_9)-15+6(I_9)=0 \text{ -----} \rightarrow 15I_9-V=15 \quad (3)$$

(7) (1)-->(2): $5I_9-15+V=18 \text{ ----} \rightarrow 5I_9+V=33 \quad (4)$

(8) Finally, (3)+(4) yields $20I_9=48$. Therefore, $I_9=2.4 \text{ [A]}$

Alternative Way: Assume that you choose CW look for left loop and CCW look for right loop:

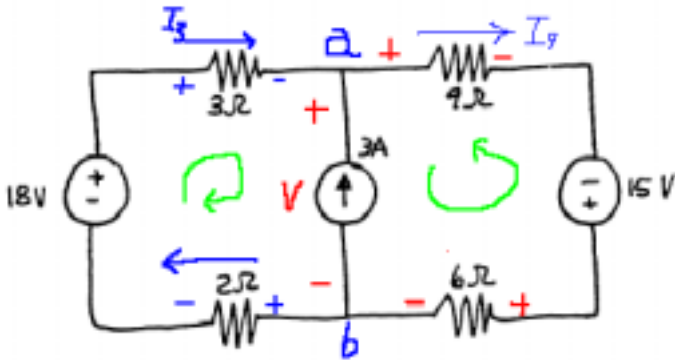

Then, the KVL equation (looking only polarities!) would be:

$$V-6I_9+15-9I_9=0 \text{ ----} \rightarrow 15I_9-V=15 \text{ ----[Same as (3) above?]}$$

So the direction of look does not make any difference.

Just keep in mind that:

- KVL is about voltage and
- it's, then, about voltage polarity.
- The voltage polarity determines the signs of the voltages in a loop.