

**Group: 7**  
**Course:** Network Analysis  
**Instructor:** Dr. Charles Kim  
**Date:** April 25, 2008

## **Final Circuit Design Report**

**Group 7 members:**  
Ashley Wells  
Danah Warren  
Oluwayemisi Sonoiki

## **INTRODUCTION**

So far in the class before we started the project, we had studied a lot of tools and theories in the laboratory. We had also learned a couple of methods that we thought would enable us to solve this “black-box” problem. However, one theory that came to mind as soon as one sees this problem is the Thevenin’s theorem. We are aware that with this theorem, we can simplify complicated circuits. One also thinks about the Maximum Power transfer theorem with which we can figure out how to deliver maximum power to a load. However the Comparator- method that we thought was best in building the project was discovered in the course of implementing the project.

## **PROJECT STATEMENT**

The concept of the black box, we think, is used to help us understand that any of the three resistors contained in the box could be connected in three or more forms. The circuit has two terminals to which we can attach a circuit which we are to build and then this built circuit would be used to figure out which of the connections is actually present in the box at a particular point in time. The question of why Thevenin’s theorem should be used comes in here however, it would later be explained.

We feel that our instructor made use of the “black box” term to make it clear to us that the contents of the box cannot be seen however, he gave us an idea of what was in the box. Basically, the aim of the project is to attempt to figure out the best possible circuit that would detect the exact type of connection of the three resistors that exists in the box.

Since we cannot open the box and can only access it with two terminals which are like output terminals, we were notified that a nine volt source exists in the box and we were also given the freedom to attach anything to this box as long as it is something that could be easily acquired from the school’s Electrical Engineering laboratory.

After giving the circuit serious thoughts and considerations, we came up with ideas such as:

1. Connecting different components together such as Comparators, Capacitors and LEDs as required, to the output terminal.
2. Connecting resistors to the output terminals so that the current that flows out of the box through each of our added resistors can be used to find out what kind of connections are present.
3. No matter the type of method we eventually go for, we found out that the use of a measuring instrument such as a Digital Multimeter would be important in measuring varying voltage, current and resistance values at various stages in the project. A question then arises, which is very important to how this project is done. What is the value of the resistance and the voltage across the terminals in each case due to the combination of resistors present in the black box? We went on to analyze each of these cases using techniques learned in class.

No matter how complicated we might connect these three resistors, Thevenin's theorem makes us to understand that we can imagine the whole circuit as just a single voltage source in series with a single resistor in the black box. Any measurements taken from the given two terminals from this imaginary circuit would be the same as that of the black box itself. It means that if we could find out what this equivalent voltage and resistance is for each case, we could proceed and build the circuit.

For the first case 1-1-1, we noted that the three resistors were connected to form a delta; a nine volt source was connected in parallel with one of the resistors while the two terminals were taken from the two ends of another resistor. When a value of resistance which would be used for the project is chosen, we could then proceed to calculate the values of  $V_{\text{thevenin}}$ ,  $i_{\text{short circuit}}$  and  $R_{\text{thevenin}}$ . It is noted that whenever we have these calculated values, then we should have our Red LED of the circuit, turn on.

For the second case, 1-0-2, we noted that it varied slightly from the first in that one of the resistors, the one across the voltage source is now taken to the terminal A. By deactivating the nine-volt source, we can

also in this case, find the values of V-thevenin, i-short circuit and R-thevenin. For this case, the Green light would go on.

The third case 3-0-0 or 0-0-3 has three resistors in parallel and then a nine volt source either connected to one of the terminals that for to the output in the 0-0-3 case or left hanging in the 3-0-0 case.

In analyzing this third case, we found out that in a situation whereby the source is left hanging, some additional voltage or a logic gate may be required somewhere in the circuit in order to have the yellow LED which symbolizes this case to go on.

However, it was not enough to simply calculate these values by hand after we determine what value of resistance to use. It was really quite beneficial to go on and simulate each of the cases using PSPICE. This helped us in seeing the correct Voltage and correct distribution across the circuit. Besides, it would help in seeing the values of V-thevenin, i-short circuit and R-thevenin.

After considering the various options available to us, we found out that it would be a good idea to use the comparator as a means of determining which LED goes on for what case. A comparator's functionality allows for us to check voltage values against each other and determine what goes out as an output.

As we were taught in a lab session, a comparator is an active device which requires power source to perform as defined by its input-output rule. The two inputs are connected each to (+) terminal or (-) terminal. As the name implies the comparator compare two input voltages appear at (+) input and (-) input terminals, and either close the SW or open it. With the aid of a comparator, we can then connect our circuit to LEDs in the final stages of the design with all the cases which have been considered noted and carefully implemented.

The last and least important thing that we thought of was that the resistors of the black box must be connected in such a way that they can easily be switched from one form to the other without significantly affecting any other thing in the circuit. This can be done on the breadboard by making sure than we have



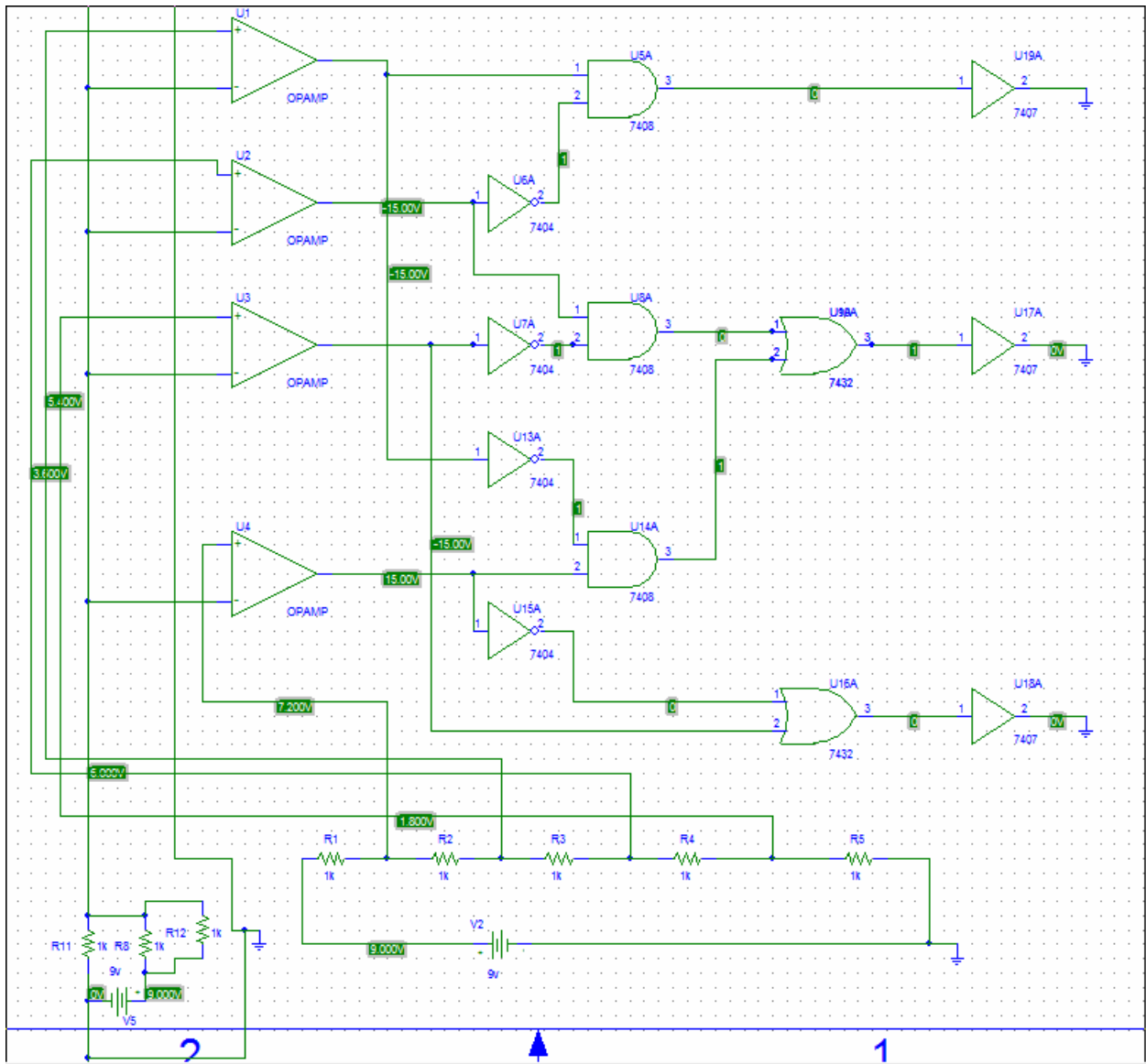

Green Light example

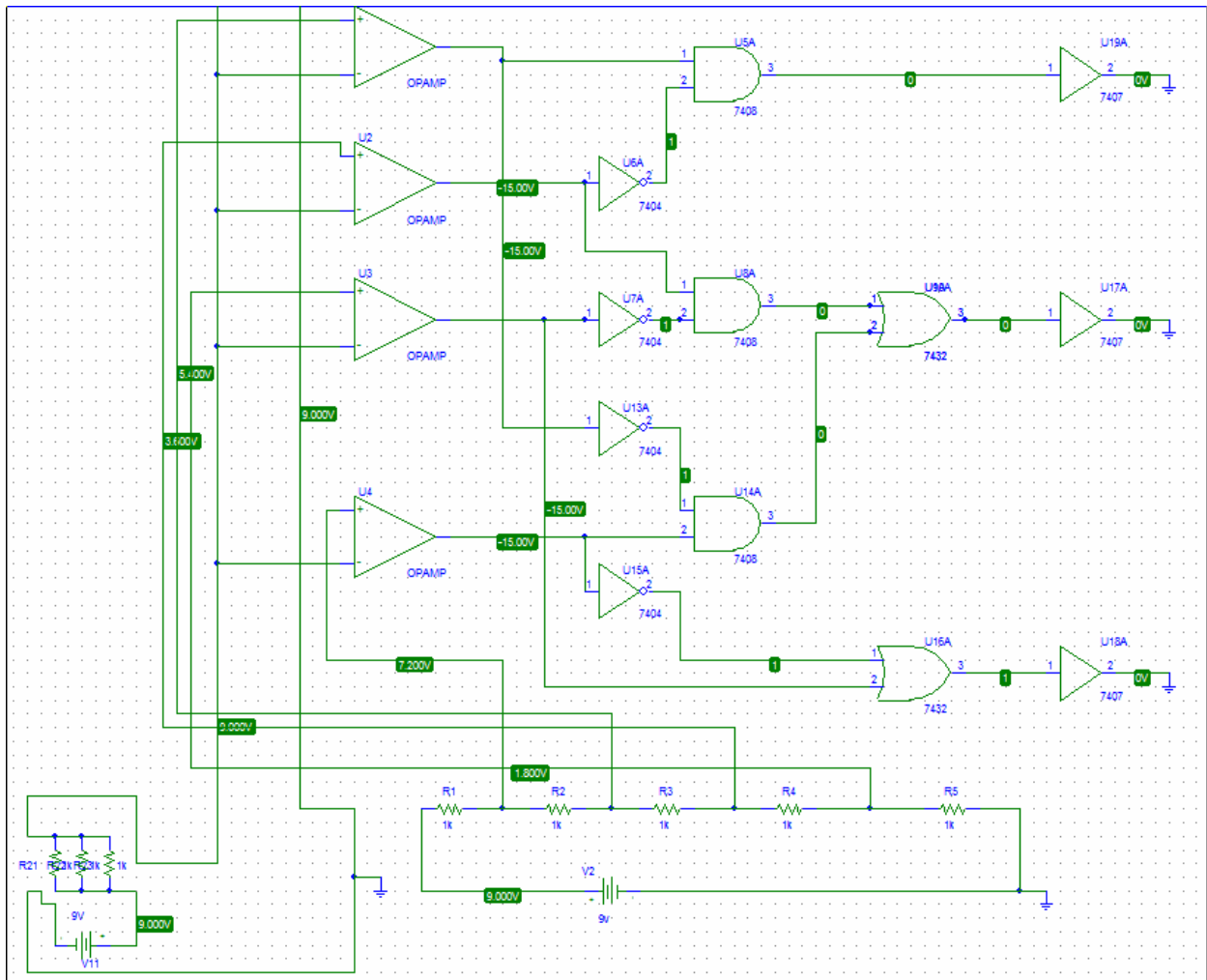

Yellow light example

### **CIRCUIT DESCRIPTION AND DISCUSSION**

We are aware that the objective of the project was to design a circuit that turns on a Red LED, a Green LED or a Yellow LED when two terminals A and B are taken from a black box and connected to two terminals in the circuit. We know that there are three LEDs and many possible arrangements of LEDs however; we were to make use of only five of these cases. The 1-1-1 case, the 1-0-2 case, the 2-0-1 case, the 3-0-0 case and the 0-0-3 case. These resistors were given these names depending on the type of connections that were present in the box.

In order to decide the best way to build this circuit, our first step was to simulate each of these five cases and we had results as follows:

Type of Combination	Voltage at A	Voltage at B (After Grounding at B)
1-1-1	4.5 volts	0 volts
2-0-1	6 volts	0 volts
1-0-2	3 volts	0 volts
3-0-0	0 volts	0 volts
0-0-3	9 volts	0 volts

We were immediately delighted that the voltages at one node (node A) varied for different combinations (as seen above) and we decided to take advantage of this and build our circuit. Out of all the ideas that we came up with, the idea of a Comparator use stood out and seemed the most feasible, convenient and reasonable therefore, we decided to go with it. As we were taught in class, a comparator has a positive terminal and a negative terminal in addition to an Output terminal. If these two terminals are supplied with two voltages of different values, the output gives us a ONE if the voltage at the positive terminal is less than that at the negative terminal, however, if that at the positive terminal is greater, the comparator is connected to ground and outputs a ZERO.

In this Our Final Circuit design, we make use of four comparators. We compare each of the node voltages to values slightly above their own values(i.e the node voltage) so that the comparator

can achieve its purpose. These values of voltage slightly higher were achieved by a voltage divider mechanism.

Instead of having to supply different voltages four different times to the circuit, we decided to supply only one voltage (9 volts) and then by connecting five resistors of 1 kilohm value each in series to this voltage source. It is seen that we have different voltages between any two resistors. From our PSpice simulation, these values are 0v, 1.8v, 3.6v, 5.4v, 7.2v and 9v respectively. We made use of the four values in the middle as the inputs to the negative terminals of the four comparators. Each of the four positive terminals were connected to terminal A which goes to the black box.

It can be seen that each of these values from the voltage divider is slightly above above our expected node voltage A. That is,  $1.8v > 0v$  ,  $3.6v > 3v$  ,  $5.4v > 4v$  and  $7.2v > 6v$ . it is also observed that the 9volt case has no value from the voltage divider that is slightly above it.

From our simulation, we connected each B node to ground. We decided not to connect C to ground because it is inside the black box and by the directions given to us. We have no control over what we can connect there. We also decided not to connect the node A to Ground because it is at this node that we have the differing voltage values that we want to use our comparator to take advantage of.

1. The 0 volt case and the 9 volt case both make the Yellow LED go on.

We figured out that the best way to make sure that only one LED goes on was to take the two wires which we now have and use them as inputs to an OR gate. Doing this for the two cases listed above gives us two wires. The third wire ( 1-1-1 case or 4 volt case) makes the Red LED to go on. By connecting each of these three wires, to a 330 ohm resistor and then to the LED before connecting it to ground, our circuit is COMPLETE.

Reasonable changes made to the initial circuit design includes the inclusion of more inverters to verify more cases before connecting to OR gates and then the exclusion of the verification process after we have our three OUTPUT wires. We figured out that if we build the circuit meticulously, there would be no need to include a verification process after having our three outputs. Last but not the least was the reversal of the 9 volt source in the black box further prompting us and making it clearer to ground our black box at node B.

### **WHY OUR DESIGN IS THE TOP DESIGN OF THE CLASS.**

As a group, we set out to achieve a goal of figuring this out and building it with a goal of coming up with not just a working circuit but the best design possible. We kept this in our mind at every stage of the circuit building. This desire to build the best circuit of the class was just enough to keep us in the lab at night while others were asleep, trying to build the circuit even long before we had simulated it on PSPICE.

We made maximum use of time allocated to complete the reports that were due at various stages in the design, revising the report over and over again until such reports were almost due then turning it in convinced that we had given our possible best. As a group, we can theoretically prove that this circuit could be completed in less than four chips however; we would confidently stand by our four-chip

Comparator method because we think it is the best method and it relates more to what we have learned in class.

Talking about the final design in itself, our design made use of only four chips. The idea of using the four designated chips were decided after we had attempted building it in at least six other ways which we think were logically right. Alas! We found out that such methods would not help matters, we were able to learn a lot from other methods but such methods did not give us our desired results.

Our group also made effective and maximum use of simulation tools and theories (such as Comparators and Voltage dividers) learned in the lab. We learned a whole lot about simulating on PSPICE and the use of comparators. Looking at all the things we learned because of the different methods we tried before coming up with the final design, we can boldly say that in terms of things learned in the course of the project execution, our group learned the most. This knowledge gained would be effectively applied in future circuit designs that we might encounter.

## **CONCLUSION**

To conclude, considering the time put into the project, the effort put into the execution, the maximum use of time, the exploration of other design methodologies, the fact that we can prove that our design is the best method (but not in terms of number of chips) and the kind of knowledge gained from diligently working on the project for long hours; relative to other groups, not only is our design the best design but our method of approach and method of execution are also the best.