

CIRCUIT DESIGN PROJECT

GROUP 4:

Rotimi Iziduh

Sharonda Harmon

Marc Inniss

Objective

Our project's primary objective was to construct a circuit capable of detecting the current resistor combination in a black box. The only access provided to the black box was via two terminals A and B. The current resistor combination was to be indicated with a red, yellow, and green LED respectively. There were 5 possible resistor combinations: 1-1-1, 2-0-1, 1-0-2, 3-0-0, and 0-0-3. The 1-1-1 combination was to be indicated by the red LED, the 2-0-1 and 1-0-2 combinations were indicated by the green LED, and the 3-0-0 and 0-0-3 combinations were to be indicated by the yellow LED.

Design Process

We followed a highly formalized process to accomplish the stated objectives of the project. We began by brainstorming possible solutions to the problem. During this stage, no suggestions were considered ridiculous and we definitely contemplated some outlandish approaches. We then selected the best idea and utilized it in developing our initial circuit design. We then proceeded to critically examine this initial design and found a number of flaws and weaknesses. We corrected these flaws, made some modifications to the circuitry, and arrived at our final design. This final design was then simulated using PSpice in order to verify correctness. Once this was completed, we were ready to commence the implementation of our solution to the problem.

Implementation

Our solution to the problem was based on an extensive usage of the node voltage values at the available black box terminals. We carried out simulations with PSpice and arrived at the following node voltage values shown in Table 1 below.

TABLE 1

Resistor Combination	Node Voltage at Terminal A	Node Voltage at Terminal B
1-1-1	4.5	0
2-0-1	3	0
1-0-2	6	0
3-0-0	9	0
0-0-3	0	0

As can be seen from the table above, the node voltage at terminal B remains constant for all resistor combinations. We therefore hinged our circuit operations on the node voltages at terminal A. Our circuit essentially consisted of a series of comparators, resistors and TTL parts. We utilized the comparators to compare the node voltages at A to specific reference voltages. The resistors were utilized in generating the reference voltages with the help of extensive applications of the voltage divider rule. We utilized the logic gates to precisely determine the current resistor state based on the results of the comparator operations. A graphical depiction using PSpice is shown below of our final circuit.

FINAL CIRCUIT

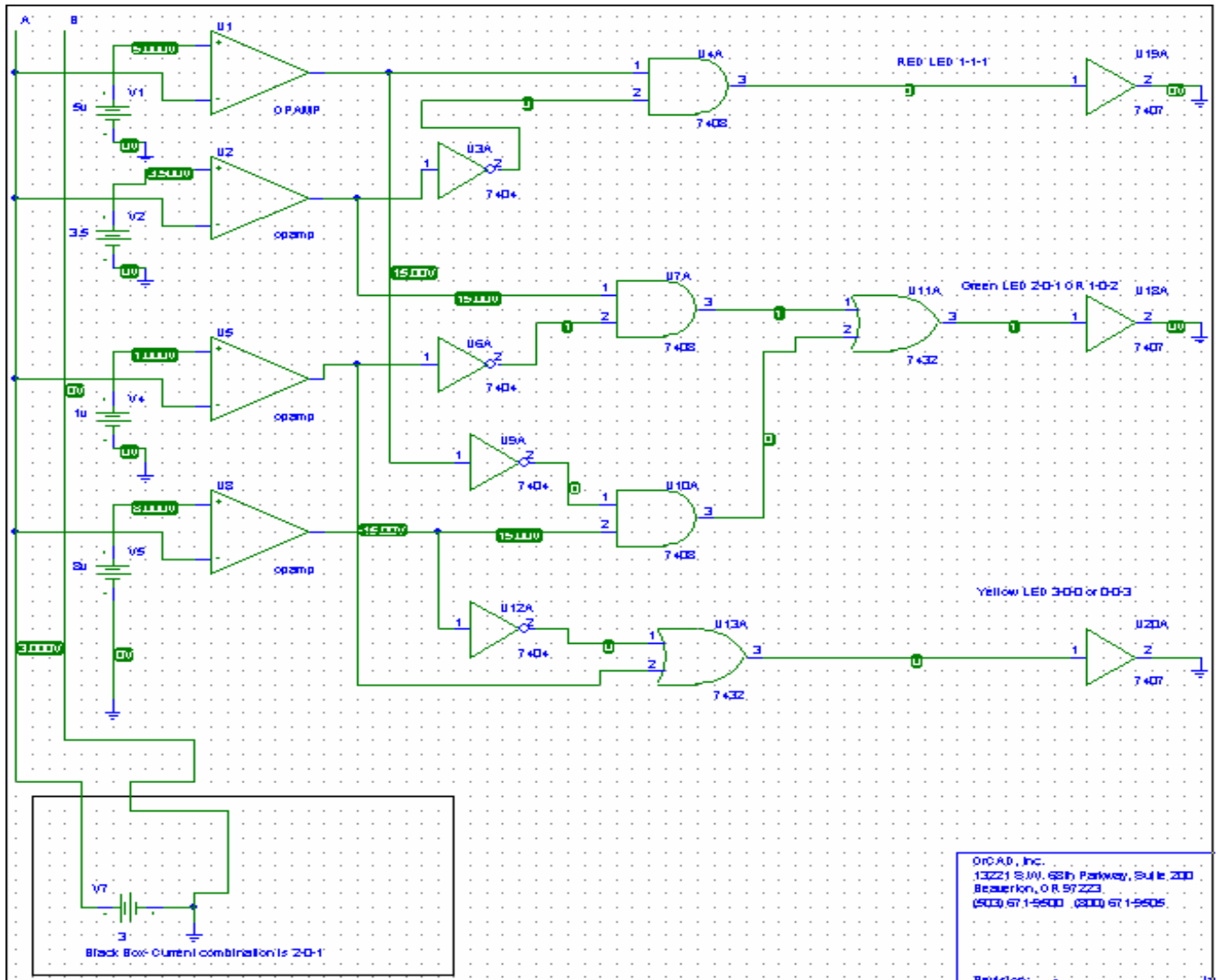

In order to ease understanding of the operation of our circuit, let us consider a case where the black box resistor combination is set to 2-0-1. Referring back to Table 1, the nodal voltages are 3v and 0v at terminals A and B respectively. The circuit utilizes the second comparator, which outputs 1 when the value at terminal A is less than 3.5v. The circuit then utilizes the third comparator which outputs a zero when the value at terminal A is greater than 1. This zero output

from the third comparator is then complemented and ANDed with the 1 output from the second comparator. The net effect of these operations is to verify that the voltage at node A is greater than 1v but less than 3.5v, conditions which are satisfied in this case because the voltage at A for the 2-0-1 combination is 3v. The output from the AND gate is then ORed with the output from testing whether we are in the 1-0-2 combination. This OR operation ensures that either the 2-0-1 combination or the 1-0-2 combination lights the green LED as stated in the project specifications. The result from this OR operation is a binary 1 output which then lights the green LED, thus achieving the intended purpose. A key facet of our circuit operations was the addition of tolerance to the reference voltages. This ensures that the circuit will still work despite small variations in voltage that may occur due to resistor and human, and instrumentation errors. Construction of the circuit on the breadboard was a fairly straightforward process. The only difficulty we initially encountered was in fully understanding the nature of the LM339 comparators. This is because when the comparator's output is set to a binary high; the voltage that is output is actually a low voltage. This problem was easily solved by complementing the outputs from the LM339.

Demonstration

The completed circuit was then presented to Dr. Kim for testing. Unfortunately, our circuit did not work on the first attempt. This was very disconcerting because the circuit had worked moments earlier. We tinkered with the circuit for some time but all hope seemed lost. We then spotted the lack of a ground terminal connected to the terminal B of the black box. Once this connection flaw was spotted and corrected, the circuit performed perfectly as expected. Our team demonstrated great courage and team spirit to overcome the initial shock of failure of

the first demonstration. We were able to refocus, and work as a team to find an effective solution.

*******Circuit Supreme*******

1. Circuitry: the uncomplicated nature of the circuitry
2. Simplicity: others understand our design
3. Optimization: circuit design is efficient
4. Reproduction: easy to reproduce
5. Budget Friendly: components are very inexpensive

There are numerous reasons why our circuit is the best among all those presented. One primary reason is because Group 4 made it. But seriously we had one of the smallest, most understandable, neatly configured designs presented. It is our belief that with the simplicity of our circuit design that we could take any up and coming freshman in engineering, pitch them the project, hand them our report and supporting documents, and they'd be able to reproduce this solution in no time. In circuit design optimization and simplicity is key and we were able to achieve both in our design. This is in stark contrast to other solutions presented in which utilized complex and expensive TTL such as decoders and multiplexers. There was no harm done with the use of these costly parts since this was a project and these parts minimized the size of the circuit. But if we used a consumer as a judge, since all solutions consisted of the aforementioned functionalities, our circuit would be considered top pick since we demonstrated the same

functions at a lower price. Same usage, lower price defines all budget friendly people looking to optimize their dollar.

The presence of tolerance ranges in our circuit design also gives us an edge over the other teams. This advantage is due to the rugged and durable nature conferred on our circuit by the tolerance ranges. As a result, our circuit can still perform effectively under the adverse conditions, which typify most practical circuit usage. So just as a recap we will firmly state that our “CIRCUIT SUPREME” is simple, easy to understand and reproduce, efficient, and budget friendly! What more could you ask for?! It is therefore our firm belief that while the other teams also performed excellently, our circuit design and overall team performance place us at the top of the pile. Remember: “Optimization and simplicity is key.” (Sharonda D. Harmon)

Conclusion

This project was a great opportunity to explore our power as students and our ability to adapt and compensate for the unknown. It provided us the opportunity to apply concepts we learnt in digital systems class and lab along with network analysis class and lab to a real world problem. We were also able to master the nuts and bolts of circuit construction, circuit debugging, and PSpice usage. It was very refreshing to see that theoretical concepts such as the node voltage method actually have practical applications and are not just meant to torture students (smile Dr. Kim). We were also exposed to a basic form of the product development cycle which is an invaluable experience. The project also helped enhance our teamwork skills and provided a means to get better acquainted with each other. Overall, the project, challenging at times, was immensely beneficial and we are very grateful for the opportunity provided.