

Class Note 25: Second-Order Circuits

A. Preface

1. A second-order circuit is a circuit environment where an inductor and a capacitor are present simultaneously.
2. The second-order circuit analysis is, in this class, is limited to one loop (series RLC) or one non-reference node (parallel RLC) case.
3. PSPICE analysis practice is encouraged.

B. Solution of a Second-Order differential Equation (part 1: solution for forced function)

1. Let's change equations (1) and (2) to a more general second-order differential equation form:

$$\frac{d^2x(t)}{dt^2} + a_1 \frac{dx(t)}{dt} + a_2x(t) = K \text{ -----(3)}$$

2. As we did in the first-order analysis, the solution of the equation (3) is:

$$x(t) = x_p(t) + x_c(t)$$

where, $x(t) = x_p(t)$ is a solution to $\frac{d^2x(t)}{dt^2} + a_1 \frac{dx(t)}{dt} + a_2x(t) = K$ -----(3a)

and $x(t) = x_c(t)$ is a solution to $\frac{d^2x(t)}{dt^2} + a_1 \frac{dx(t)}{dt} + a_2x(t) = 0$ -----(4)

3. Let's observe equation (3a) for a while. Since the right hand side is a constant K, therefore $x_p(t)$ must be a constant (at left hand side). Let say $x_p(t)=C$ (C is a constant), then the left hand side is: a_2C . Therefore, $x_p(t) = C = \frac{K}{a_2}$.

4. The, the complete solution of equation (3) is of the form:

$$x(t) = x_p(t) + x_c(t) = \frac{K}{a_2} + x_c(t)$$

5. The solution of the homogeneous equation for $x_c(t)$ [eq. (4)] starts in the next section.

C. Solution of a Second-Order differential Equation (part 2: solution for homogeneous eq.)

1. For simplicity (you will see why soon), let's rewrite the equation (4), by simple substitutions for $a_1 = 2\alpha$ and $a_2 = \omega_o^2$, in the form of:

$$\frac{d^2x(t)}{dt^2} + 2\alpha \frac{dx(t)}{dt} + \omega_o^2 x(t) = 0 \text{ -----(5)}$$

*Note: For this revised equation form, $x_p(t) = \frac{K}{\omega_o^2}$ since $a_2 = \omega_o^2$.

2. We assume a solution that: $x_c(t) = Ae^{st}$
3. The substitution of the assumed solution into equation (5) yields

$$s^2 Ae^{st} + 2\alpha s Ae^{st} + \omega_o^2 Ae^{st} = 0$$

4. Simplification of the above equation yields to: $(s^2 + 2\alpha s + \omega_o^2) Ae^{st} = 0$

Since $x_c(t) = Ae^{st}$ cannot be zero, $s^2 + 2\alpha s + \omega_o^2 = 0$ -----(6)

5. The equation (6) is called the characteristic equation, where

α is referred to *Neper Frequency*

w_o is referred to *Undamped Natural Frequency* (or *Resonant Frequency*)

and $\left(\frac{\alpha}{w_o}\right)$ is referred to *Exponential Damping Ratio*.

6. If the characteristic equation is satisfied, then, the assumed solution $x(t) = Ae^{st}$ is correct.

7. Employing the quadratic formula, the roots for the characteristic equation are:

$$s = \frac{-2\alpha \pm 2\sqrt{\alpha^2 - w_o^2}}{2} = -\alpha \pm \sqrt{\alpha^2 - w_o^2}$$

8. Therefore, the two roots are:

$$s_1 = -\alpha + \sqrt{\alpha^2 - w_o^2} \quad \text{and} \quad s_2 = -\alpha - \sqrt{\alpha^2 - w_o^2}$$

9. This means that we have two solutions of the homogeneous equation:

$$x_1(t) = A_1 e^{s_1 t} \quad \text{and} \quad x_2(t) = A_2 e^{s_2 t}$$

10. Note that the sum of two solutions is also a solution. Therefore, in general the solution of the homogeneous equation is of the form:

$$x_c(t) = A_1 e^{s_1 t} + A_2 e^{s_2 t} \text{ -----(7)}$$

11. Finally, the solution for the original second-order equation of

$$\frac{d^2 x(t)}{dt^2} + 2\alpha \frac{dx(t)}{dt} + w_o^2 x(t) = K$$

is:

$$x(t) = \frac{K}{w_o^2} + x_c(t) = \frac{K}{w_o^2} + A_1 e^{s_1 t} + A_2 e^{s_2 t}$$

$$\text{with, } s_1 = -\alpha + \sqrt{\alpha^2 - w_o^2} \quad \text{and} \quad s_2 = -\alpha - \sqrt{\alpha^2 - w_o^2}.$$

12. From the solution, we can easily see the final value: $x(\infty) = \frac{K}{w_o^2}$.

D. Examination of the solution of the homogeneous equation: Natural Frequency Analysis

1. Let's have a closer examination of the roots of the characteristics roots:

$$s_1 = -\alpha + \sqrt{\alpha^2 - w_o^2} \quad \text{and} \quad s_2 = -\alpha - \sqrt{\alpha^2 - w_o^2}$$

2. The roots s_1 and s_2 are called the natural frequencies because they determine the natural (unforced) response of the network.

3. We see that the roots are dependent upon the value of $(\alpha^2 - w_o^2)$.

4. If $\alpha^2 = w_o^2$: the roots are **real and equal** --> "Critically Damped"

If $\alpha^2 > w_o^2$: the roots are **real and unequal** --> "Overdamped"

If $\alpha^2 < w_o^2$: the roots are **complex numbers** --> "Underdamped"

5. “Critically Damped” case: (real and equal s)

(a) Condition: $\alpha^2 = \omega_o^2 \Rightarrow s_1 = s_2 = -\alpha$

(b) Solution Form: $x(t) = x(\infty) + D_1 t e^{-\alpha t} + D_2 e^{-\alpha t}$

[Note: $x(t) = x(\infty) + A_1 e^{-\alpha t} + A_2 e^{-\alpha t} = (A_1 + A_2) e^{-\alpha t} = A_3 e^{-\alpha t}$. This simple form,

however, in general does not satisfy the two initial conditions, i.e., $x(0)$ and $\left. \frac{dx(t)}{dt} \right|_{t=0}$

with the single constant A_3 . After applying an approach for repeated roots, the solution for critically damped case is of the form: $x(t) = x(\infty) + A_3 e^{-\alpha t} (A_1 + A_2 t)$]

(c) Constraints (equations to find the two coefficients, D_1 , and D_2):

i) $x(0) = x(\infty) + D_2$

ii) $\left. \frac{dx(t)}{dt} \right|_{t=0} = D_1 - \alpha D_2$

6. “Overdamped” case: (real and unequal s)

(a) Condition: $\alpha^2 > \omega_o^2$

(b) Solution: $x(t) = x(\infty) + A_1 e^{s_1 t} + A_2 e^{s_2 t}$

(c) Constraints (or equations to find two coefficients A_1 and A_2)

i) $x(0) = x(\infty) + A_1 + A_2$

ii) $\left. \frac{dx(t)}{dt} \right|_{t=0} = s_1 A_1 + s_2 A_2$

7. “Underdamped” case: (complex s)

(a) Condition: $\alpha^2 < \omega_o^2$. Also define $\omega_d = \sqrt{\omega_o^2 - \alpha^2}$

The roots are rewritten as:

$$s_1 = -\alpha + j\sqrt{\omega_o^2 - \alpha^2} = -\alpha + j\omega_d \quad \text{and} \quad s_2 = -\alpha - j\sqrt{\omega_o^2 - \alpha^2} = -\alpha - j\omega_d$$

Then, the solution can be rewritten as:

$$x(t) = x(\infty) + A_1 e^{-(\alpha - j\omega_d)t} + A_2 e^{-(\alpha + j\omega_d)t}$$

$$= x(\infty) + e^{-\alpha t} [A_1 e^{j\omega_d t} + A_2 e^{-j\omega_d t}]$$

$$= x(\infty) + e^{-\alpha t} [A_1 \{\cos \omega_d t + j \sin \omega_d t\} + A_2 \{\cos \omega_d t - j \sin \omega_d t\}]$$

$$= x(\infty) + e^{-\alpha t} [(A_1 + A_2) \cos \omega_d t + j(A_1 - A_2) \sin \omega_d t]$$

$$= x(\infty) + e^{-\alpha t} [B_1 \cos \omega_d t + B_2 \sin \omega_d t]$$

(b) The solution form: $x(t) = x(\infty) + e^{-\alpha t} [B_1 \cos \omega_d t + B_2 \sin \omega_d t]$

(c) Constraints (Coefficient equations)

i) $x(0) = x(\infty) + B_1$

ii) $\left. \frac{dx(t)}{dt} \right|_{t=0} = -\alpha B_1 + \omega_d B_2$

Second-Order Equation Summary Table

Second-Order Differential Equation	$\frac{d^2x}{dt^2} + 2\alpha \frac{dx}{dt} + \omega_0^2 x = K$			
Final Value	$x(\infty) = \frac{K}{\omega_0^2}$			
Characteristics Roots	$s_1 = -\alpha + \sqrt{\alpha^2 - \omega_0^2} \quad \text{and} \quad s_2 = -\alpha - \sqrt{\alpha^2 - \omega_0^2}$			
S o l u t i o n s	Damping Types	Overdamped case	Underdamped case	Critically Damped case
	Condition	$\alpha^2 > \omega_0^2$	$\alpha^2 < \omega_0^2$	$\alpha^2 = \omega_0^2$
	Solution Form $x(t) =$	$x(\infty) + A_1 e^{s_1 t} + A_2 e^{s_2 t}$	$x(\infty) + B_1 e^{-\alpha t} \cos \omega_d t + B_2 e^{-\alpha t} \sin \omega_d t$	$x(\infty) + D_1 t e^{-\alpha t} + D_2 e^{-\alpha t}$
	Coefficient Determination Relationship	$x(0) = x(\infty) + A_1 + A_2$ $\frac{dx(t)}{dt} \Big _{t=0} = s_1 A_1 + s_2 A_2$	$x(0) = x(\infty) + B_1$ $\frac{dx(t)}{dt} \Big _{t=0} = -\alpha B_1 + \omega_d B_2$ $\omega_d = \sqrt{\omega_0^2 - \alpha^2}$	$x(0) = x(\infty) + D_2$ $\frac{dx(t)}{dt} \Big _{t=0} = D_1 - \alpha D_2$

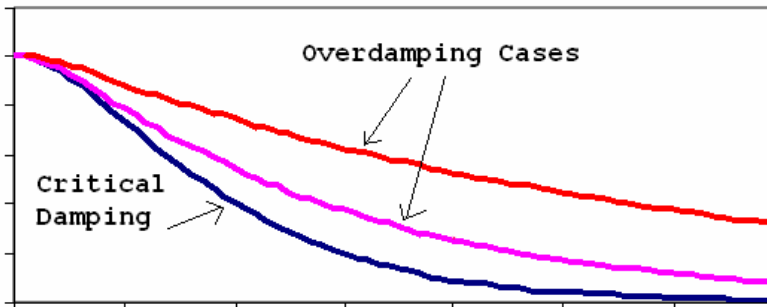
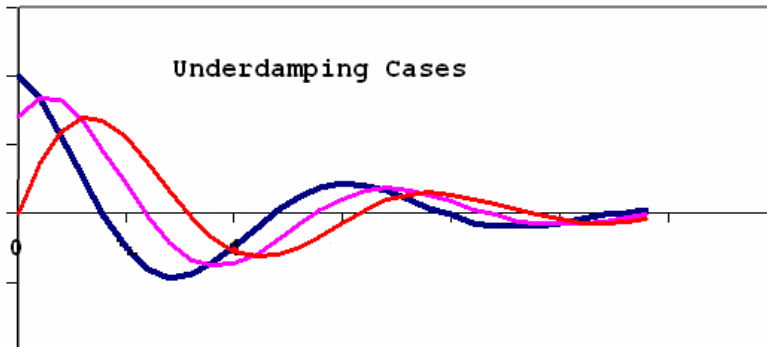

E. Basic Circuit Equation of Second-Order Circuit

1. Let's first consider a parallel RLC circuit powered by a DC current source.

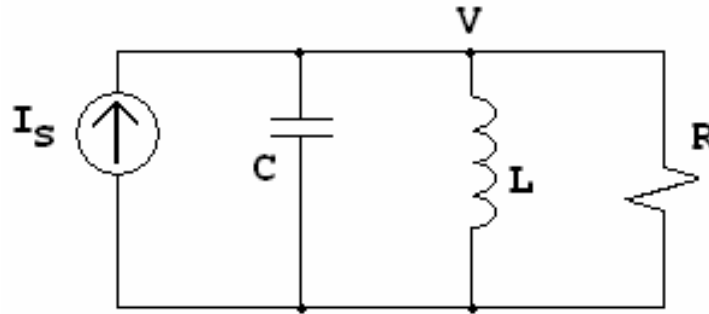

2. Let's assume that there is no energy initially stored in the capacitor and inductor.

3. The node voltage equation is:

$$-I_s + \frac{v}{R} + \frac{1}{L} \int_{t_0}^t v dx + C \frac{dv}{dt} = 0 \rightarrow \frac{v}{R} + \frac{1}{L} \int_{t_0}^t v dx + C \frac{dv}{dt} = I_s$$

4. By derivation with respect to time t , we have:

$$C \frac{d^2v}{dt^2} + \frac{1}{R} \frac{dv}{dt} + \frac{v}{L} = 0 \quad \text{or} \quad \frac{d^2v}{dt^2} + \frac{1}{RC} \frac{dv}{dt} + \frac{v}{LC} = 0 \text{-----(1)}$$

From the general 2nd order differential equation, $\frac{d^2x(t)}{dt^2} + 2\alpha \frac{dx(t)}{dt} + \omega_o^2 x(t) = K$,

We see that:

(a) $2\alpha = \frac{1}{RC} \rightarrow \alpha = \frac{1}{2RC}$: The damping coefficient is determined by half of $1/RC$ (i.e., half of the $1/\tau$)

(b) $\omega_o^2 = \frac{1}{LC} \rightarrow \omega_o = \frac{1}{\sqrt{LC}}$: The Resonant frequency is determined by \sqrt{LC} .

(c) Damping conditions:

i) critically damping, if $\left(\frac{1}{2RC}\right)^2 = \frac{1}{LC}$

ii) over damping, if $\left(\frac{1}{2RC}\right)^2 > \frac{1}{LC}$

iii) under damping, if $\left(\frac{1}{2RC}\right)^2 < \frac{1}{LC}$, oscillation frequency $\omega_d = \sqrt{\frac{1}{LC} - \left(\frac{1}{2RC}\right)^2}$

5. Let's now consider a series RLC circuit powered by a DC voltage source.

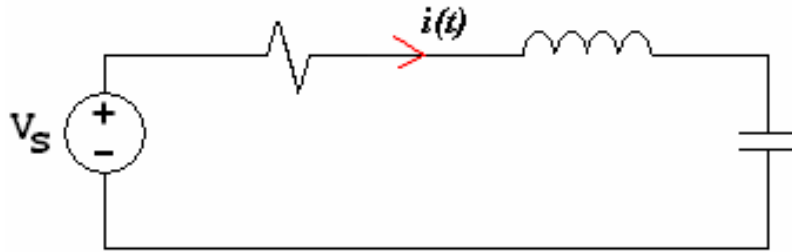

6. Again, let's assume that there is no energy initially stored in the capacitor and inductor.

7. The loop KVL equation for the current is:

$$-V_s + Ri + \frac{1}{C} \int_{t_0}^t i(x) dx + L \frac{di}{dt} = 0 \rightarrow Ri + \frac{1}{C} \int_{t_0}^t i(x) dx + L \frac{di}{dt} = V_s$$

8. By derivation with respect to time t , we have:

$$L \frac{d^2 i}{dt^2} + R \frac{di}{dt} + \frac{i}{C} = 0 \rightarrow \frac{d^2 i}{dt^2} + \frac{R}{L} \frac{di}{dt} + \frac{i}{LC} = 0 \text{ -----(2)}$$

From the general 2nd order differential equation, $\frac{d^2 x(t)}{dt^2} + 2\alpha \frac{dx(t)}{dt} + \omega_o^2 x(t) = K$,

We see that:

(a) $2\alpha = \frac{R}{L} \rightarrow \alpha = \frac{R}{2L}$: The damping coefficient is determined by half of R/L (i.e., half of the $1/\tau$)

(b) $\omega_o^2 = \frac{1}{LC} \rightarrow \omega_o = \frac{1}{\sqrt{LC}}$: The Resonant frequency is determined by $\text{sqrt}(LC)$.

(c) Damping conditions:

i) critically damping, if $\left(\frac{R}{2L}\right)^2 = \frac{1}{LC}$

ii) over damping, if $\left(\frac{R}{2L}\right)^2 > \frac{1}{LC}$

iii) under damping, if $\left(\frac{R}{2L}\right)^2 < \frac{1}{LC}$, oscillation frequency $\omega_d = \sqrt{\frac{1}{LC} - \left(\frac{R}{2L}\right)^2}$

9. We can see that the equation for the node voltage in the parallel RLC [equation (1) above] and the equation for the loop current in the series RLC [equation (2) above] are identical: a second-order differential equation with constant coefficients.

F. Parallel RLC Natural Response Example

Consider the parallel RLC circuit shown below. Find the node voltage $v(t)$ and the current through the inductor $i_L(t)$.

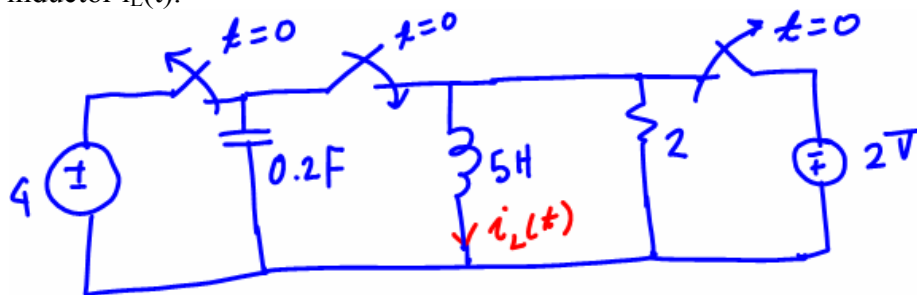

SOLUTION:

(Sol) $t < 0$:

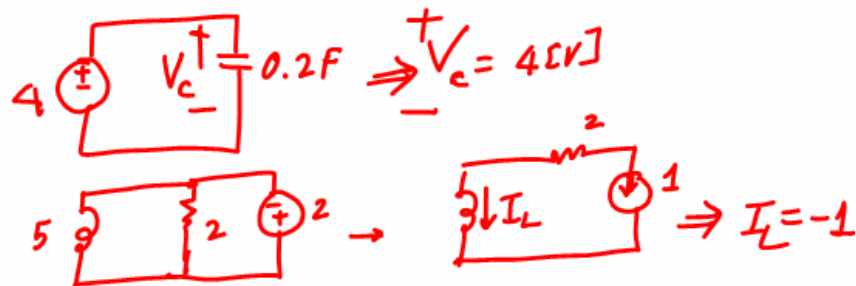

$t > 0$: $V_c(0) = 4$, $i_L(0) = -1$

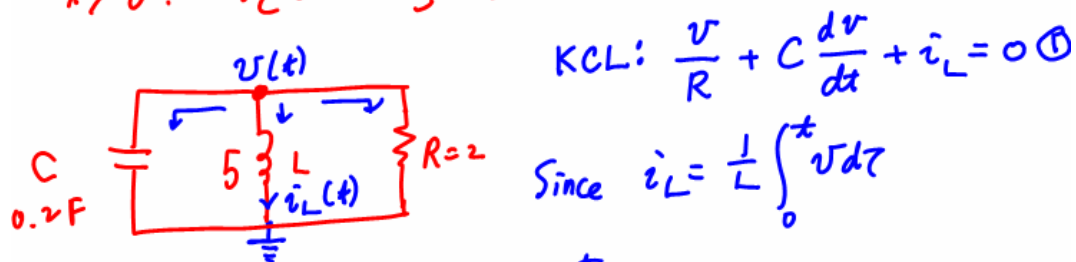

$$\textcircled{1} \rightarrow \frac{v}{R} + C \frac{dv}{dt} + \frac{1}{L} \int_0^t v d\tau$$

$$\downarrow \frac{d}{dt}$$

$$C \frac{d^2v}{dt^2} + \frac{1}{R} \frac{dv}{dt} + \frac{1}{L} v = 0$$

$$\downarrow$$

$$\underline{\underline{\frac{d^2v}{dt^2} + \frac{1}{RC} \frac{dv}{dt} + \frac{1}{LC} v = 0}} \quad \textcircled{2}$$

Since $R=2$, $C=0.2$, $L=5$

$$\frac{1}{RC} = \frac{1}{(2)(0.2)} = 2.5, \quad \frac{1}{LC} = \frac{1}{(0.2)(5)} = 1$$

$$\textcircled{2} \rightarrow \frac{d^2 v}{dt^2} + 2.5 \frac{dv}{dt} + 1 v = 0$$

$$\rightarrow 2\alpha = 2.5 \Rightarrow \alpha = 1.25, \\ \omega^2 = 1$$

Since $\alpha^2 > \omega^2$: Overdamping

Solution Form: $v(t) = \cancel{v(\infty)} + A_1 e^{s_1 t} + A_2 e^{s_2 t}$

$$s_1 = -\alpha + \sqrt{\alpha^2 - \omega^2} = -1.25 + \sqrt{1.25^2 - 1} = -0.5$$

$$s_2 = -1.25 - \sqrt{1.25^2 - 1} = -2$$

Use constraints for A_1 & A_2

$$\text{(i) } v(0) = A_1 + A_2 + v(\infty) \quad \rightarrow A_1 + A_2 = 4 \quad \textcircled{1}$$

From $v(0) = V_C(0) = 4$

$$\text{(ii) } \left. \frac{dv}{dt} \right|_{t=0} = s_1 A_1 + s_2 A_2$$

From $\textcircled{1}$: $\frac{v}{R} + C \frac{dv}{dt} + i_L = 0$

$$\frac{v(0)}{R} + C \left. \frac{dv}{dt} \right|_{t=0} + i_L(0) = 0 \rightarrow \left. \frac{dv}{dt} \right|_{t=0} = \frac{-\frac{v(0)}{R} - i_L(0)}{C} \\ = \frac{-\frac{4}{2} - (-1)}{0.2} = \underline{\underline{-5}}$$

$$\therefore \begin{cases} -0.5A_1 - 2A_2 = -5 & \textcircled{2} \\ A_1 + A_2 = 4 & \textcircled{1} \end{cases}$$

$$\left. \begin{array}{l} A_1 + 4A_2 = 10 \\ A_1 + A_2 = 4 \end{array} \right\} A_2 = 2, A_1 = 2$$

Finally

$$\begin{aligned} v(t) &= A_1 e^{s_1 t} + A_2 e^{s_2 t} \\ &= 2e^{-0.5t} + 2e^{-2t} \end{aligned}$$

G. Series RLC Natural Response Example

The switch in the circuit has been closed for a long time. At $t=0$, the switch opens. Find $i(t)$.

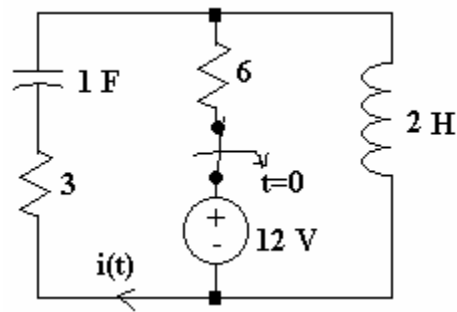

SOLUTION:

$t < 0$:

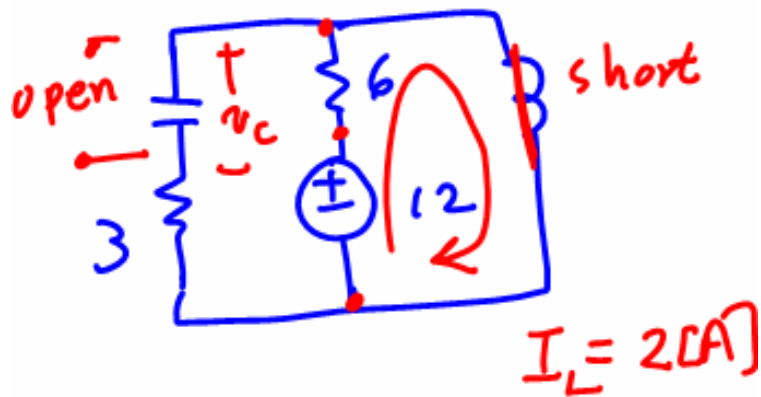

$$V_C = 0 \quad (12 - 12 = 0)$$

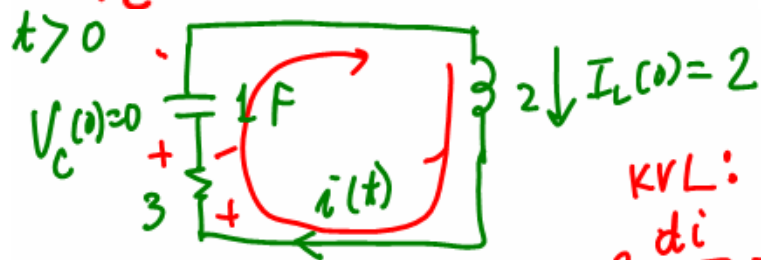

KVL:

$$2 \frac{di}{dt} + 3i + V_C = 0 \quad \textcircled{1}$$

Since $V_C = \frac{1}{C} \int i dt$

$$\textcircled{1} \quad 2 \frac{di}{dt} + 3i + \frac{1}{C} \int_0^t i dt = 0$$

↓ $\frac{d}{dt}$

$$2 \frac{d^2 i}{dt^2} + 3 \frac{di}{dt} + \frac{1}{C} i = 0$$

$$\rightarrow \frac{d^2 i}{dt^2} + \frac{3}{2} \frac{di}{dt} + \frac{1}{2} i = 0$$

$$2\alpha = \frac{3}{2} \rightarrow \alpha = 0.75$$

$$\omega^2 = \frac{1}{2}$$

$$\alpha^2 = \frac{9}{16} > \omega^2$$

overdamping.

$$i(\infty) = \frac{K}{\omega^2} = 0$$

$$\therefore i(t) = A_1 e^{s_1 t} + A_2 e^{s_2 t}$$

$$s_1 = -\alpha + \sqrt{\alpha^2 - \omega^2} = -0.75 + \sqrt{(0.75)^2 - \frac{1}{2}} = -0.5$$

$$s_2 = -\alpha - \sqrt{\alpha^2 - \omega^2} = -1$$

$$\rightarrow A_1 e^{-0.5t} + A_2 e^{-t}$$

use constraints to find A_1 & A_2

$$(i) \quad i(0) = A_1 + A_2 = 2 \quad (1) \leftarrow \text{(from } t < 0 \text{ analysis)}$$

$$(ii) \quad \left. \frac{di}{dt} \right|_{t=0} = s_1 A_1 + s_2 A_2 = -0.5 A_1 - A_2 = -3 \quad (2)$$

From

$$2 \frac{di}{dt} + 3i + V_c = 0 \quad (1)$$

$$\left. \frac{di}{dt} \right|_{t=0} = \frac{-3i(0) - v_c(0)}{2} = \frac{-3 \cdot 2 - 0}{2} = -3$$

From ① & ②

$$\left. \begin{aligned} A_1 + A_2 &= 2 \\ -0.5 A_1 - A_2 &= -3 \end{aligned} \right\} A_1 = -2, A_2 = 4$$

Finally, $i(t) = -2e^{-0.5t} + 4e^{-t}$

H. Step Response of Parallel RLC Example

Energy is stored in the circuit before the DC current source is applied, with $i_L(0) = 0.29$ [A] and $v_C(0) = 5$ [V]. Find $i_L(t)$.

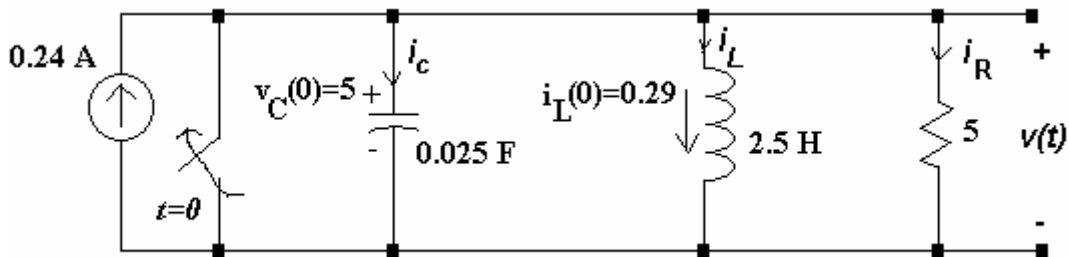

SOLUTION

I. Step Response of Series RLC Example

Find $v_C(t)$.

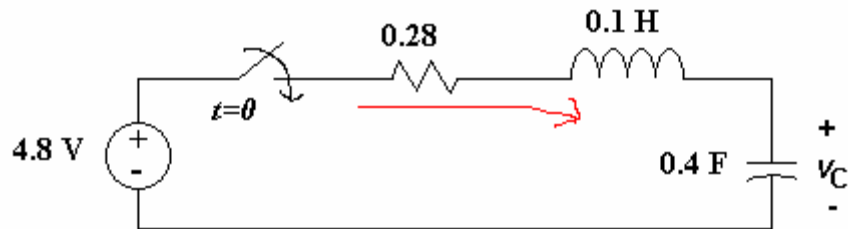

SOLUTION:



Since $v_C = \frac{1}{C} \int_0^t i d\tau$

① $\rightarrow Ri + L \frac{di}{dt} + \frac{1}{C} \int_0^t i d\tau = 4.8$

$\Downarrow \frac{d}{dt}$

$$R \frac{di}{dt} + L \frac{d^2i}{dt^2} + \frac{1}{C} [i(t) - \cancel{i(0)}] = 0$$

$$\rightarrow \frac{d^2 i}{dt^2} + \frac{R}{L} \frac{di}{dt} + \frac{1}{LC} i = 0 \Rightarrow \frac{d^2 i}{dt^2} + \frac{0.28}{0.1} \frac{di}{dt} + \frac{1}{(0.1)(0.4)} i = 0$$

$$\frac{d^2 i}{dt^2} + 2.8 \frac{di}{dt} + 25 i = 0$$

$$2\alpha = 2.8 \rightarrow \alpha = 1.4$$

$$\omega^2 = 25$$

α^2 vs $\omega^2 \rightarrow \alpha^2 < \omega^2$ Underdamping

$$i(t) = i(\infty) + e^{-\alpha t} (B_1 \cos \omega_d t + B_2 \sin \omega_d t)$$

$$\text{where } \omega_d = \sqrt{\omega^2 - \alpha^2} = \sqrt{25 - 1.4^2} = 4.8$$

$$i(\infty) = \frac{K}{\omega^2} = 0$$

$$= e^{-1.4t} (B_1 \cos 4.8t + B_2 \sin 4.8t)$$

Use constraints to find B_1 & B_2 :

$$(i) i(0) = i(\infty) + B_1 = 0 \quad \therefore \underline{B_1 = 0}$$

$$(ii) \left. \frac{di}{dt} \right|_{t=0} = -\alpha B_1 + \omega_d B_2 \quad \text{what is } \left. \frac{di}{dt} \right|_{t=0} = ?$$

From

$$\textcircled{1} -4.8 + Ri + L \frac{di}{dt} + v_c = 0$$

$$\left. \frac{di}{dt} \right|_{t=0} = \frac{4.8 - Ri(0) - v_c(0)}{L} = \frac{4.8}{L} = \frac{4.8}{.1} = 48$$

$$\therefore -1.4B_1 + 4.8B_2 = 48 \rightarrow \underline{B_2 = 10}, \underline{B_1 = 0}$$

Finally.

$$\underline{i(t) = 10 \cdot e^{-1.4t} \cdot \sin 4.8t}$$

J. RLC Response Extra Problems

1. The switch in the circuit has been in position 1 for a long time. At $t=0$, it moves from position 1 to position 2. Compute $i(t)$ for $t>0$ and use this current to determine the voltage $v(t)$.

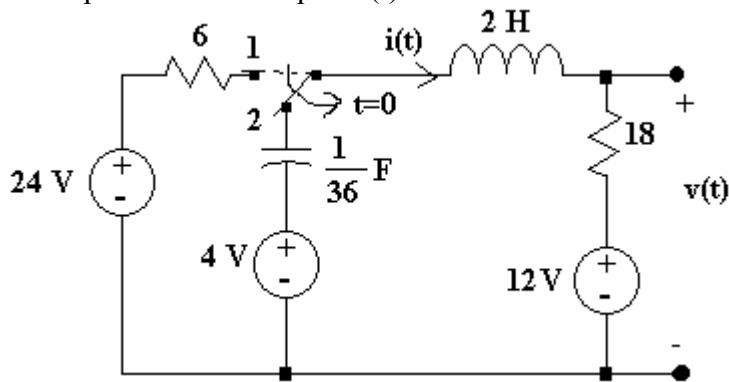

2. The switch in the circuit has been in position 1 for a long time. At $t=0$, it moves from position 1 to position 2. Compute $v(t)$ for $t>0$.

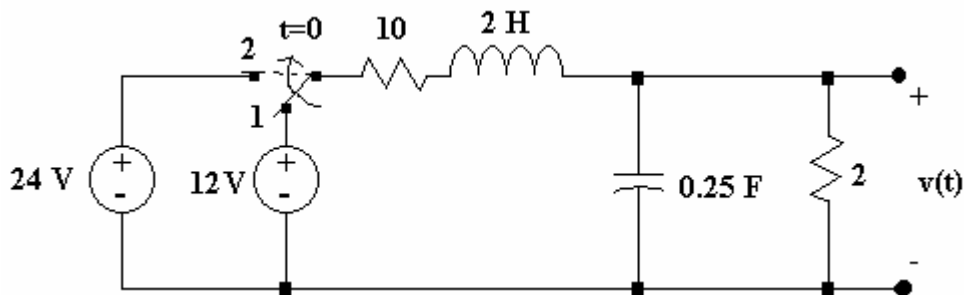

3. Find $v(t)$ and $i(t)$

