

**Design Project Proposal**

**San Diego Gas & Electric  
Microgrid Performance Simulation Project**

**Submitted by**

**Christina Cheek  
Mulugeta Damamo  
D'Angelo Woods**

**Approved by**

**Proposal Review Panel Representative:**

---

<b>Name</b>	<b>Signature</b>	<b>Date</b>
-------------	------------------	-------------

**Senior Design I Instructor:**

---

<b>Name</b>	<b>Signature</b>	<b>Date</b>
-------------	------------------	-------------

## **Introduction**

With the dawn of the 21st century comes the realization that the nation's three major interconnected power grids are aging. There exists a need for an improved system that meets the demands of today's customers while also having a better impact on the environment.

In 2007, the Energy Independence and Security Act was established in response to this increased demand for electricity and the desire for more environmentally friendly energy sources. The purpose of this policy was to be independent of foreign oil and produce green and cost-efficient power from renewable energy resources (RERs). RERs are tremendous and offer limited greenhouse emission. Individual distributed generators (DG) utilizing RERs are already in place but they can be optimized using a microgrid. Microgrids are small-scale versions of the larger interconnected grid and involve DGs supplying low-level voltage (LV) electricity from RERs. Using this system, consumers can generate electricity in their backyard and use it for their property or sell it to the utility company. In cases of disturbances, the microgrid can operate independently of the power grid and reconnect after The San Diego Gas & Electric (SDG&E) Microgrid Project was initiated to develop such a system. The Microgrid consists of information-based technologies that have the potential to increase asset utilization and reliability, optimize the design of circuit operations, operate more cost-effectively and reliably, and improve the security and reliability of electricity supply of the present power grid. Before the Microgrid project can be fully implemented, there must be proof that the Microgrid will indeed operate as described.

To adequately meet this need, it is the responsibility of Team SMART to provide a clear assessment of the cost and benefit of such technologies as well as a proof-of-concept of the Microgrid under both normal and faulted conditions. The technical background required for these tasks include basic circuit analysis, power systems analysis, and programming/simulations experience, specifically in MATLAB and power simulation tools. It is also necessary for the Team to be capable of analyzing the correlation between the cost and benefit of the Microgrid as well as providing an accurate evaluation of its environmental impact through an emissions analysis.

The goal of the SDG&E Microgrid Project is to have advanced grid technologies in place by 2020 that will facilitate a 30% reduction in greenhouse gas emissions, which includes supplying 33% of their customers' energy needs from renewable energy sources. The Team's goal is to assist SDG&E with their goals by proving the microgrid concept, evaluating the costs of such a system, evaluating the performance of the system under normal and faulted conditions, and performing a carbon emissions analysis by March 2010.

## **Problem Definition**

Our project seeks to prove the concept of a “microgrid,” while also analyzing the cost and benefits associated with implementing such a system. Following the lead of those who have developed their own microgrid and evaluated the results of such a system, Team SMART will focus on simulation of the system under normal and faulted conditions. To accomplish this we will have to design our system so that it is able to differentiate between a normal and faulted condition, maintain operation under islanded conditions, fully integrate renewable energy sources that help to reduce carbon emission, and comply with specific regulations.

### *Constraints*

- Minimize costs associated with design, implementation, and maintenance of microgrid system for customer and SDG&E
- Achieve >15% reduction in feeder peak load
- Project must be modeled, simulated, tested, and evaluated within a software-computing environment.

### *Compliance/Regulations*

There are several on-going projects that are progressing toward establishing standards and regulations specific to the microgrid concept. One of these standards is the IEEE 1547 Standard for Interconnecting Distributed Resources with Electric Power Systems which established criteria and requirements for interconnection of distributed resources with electric power systems.

A more detailed definition will be provided as more information becomes available through our external advisors.

## **Current Status of Art**

The concept of a microgrid is one that has sparked interest within both the public and private sector. Many of these projects are funded by the United States Department of Energy and most are in collaboration with local, state, and federal utilities. Team SMART has isolated three of these projects from which to learn and adopt new ideas that can benefit us in achieving our objectives. These projects are listed below:

### *CEC/DOE Energy Storage Collaboration*

When we speak of microgrids, we must discuss one of their most important functions, which is the ability to isolate loads from the main power grid. Storage capabilities are crucial during isolation because it withholds power that can be distributed locally for uninterrupted service. According to the project’s website, this project will demonstrate the use of an ultra capacitor energy storage module in support of a selection

of distributed energy resources that could potentially be configured as an electric microgrid. The California Energy Commission and the U.S. Department of Energy is sponsoring the project in order to (1) evaluate the ability of the energy storage system to improve power quality for the facilities critical loads, and (2) to demonstrate the ability of the energy storage system to isolate part of the facility without shutting down any of the critical equipment during the transition from the grid to the backup generator.

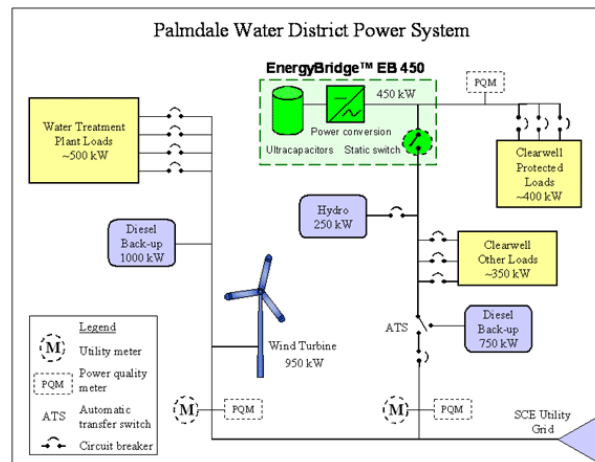

Figure E. Palmdale Water District Power System

The Team will not only gain knowledge of energy storage systems and how they relate to improved performance of a microgrid but will also be able to take advantage of the project's real-time analysis and ability to reduce peak load, thus satisfying one of our constraints. The costs and benefits involved with incorporating the zinc bromine battery based storage system will also be helpful in evaluating the economical feasibility of a microgrid system.

#### *CERTS Microgrid Test Bed Demonstration with AEP*

Demonstrated at a full-scale test bed outside Columbus, Ohio, the Consortium for Electric Reliability Technology Solutions (CERTS) sought to reduce the amount of custom engineering required for integrating renewable energy options into the microgrid. As a result, the microgrid avoids many of the current concerns associated with integrating DER, such as how many DER the system can tolerate before their collective electrical impact begins to create problems like excessive current flows into faults and voltage fluctuations. This will help the Team evaluate the practicality, costs, and emissions associated with implementing renewable energy resources into the microgrid. This project was also successful in that the electrical protection system was able to distinguish between normal and faulted operation, conditions under which the Team will also need to simulate and test.

## *SDG&E Beach Cities Microgrid Project*

San Diego Gas & Electric's (SDG&E) project will be used as a guide for the Team as we complete similar objectives. The Beach Cities Project involves a proof-of-concept and cost/benefit analysis, as well as a greater than %15 feeder peak load reduction requirement. While SDG&E's project will involve incorporating advanced sensors, controls, and communications, our focus will be on the concept itself and how much it would cost. Tom Bialek, Chief Engineer for the Beach Cities Project, will also be contacted for additional assistance as we move forward with our project.

### **Engineering Approach**

Our project will consist of constructing a small-scale power system using the SimPowerSystems toolbox within our MATLAB/Simulink environment for analysis and testing. All necessary data as it relates to our power system should be obtained through these simulations. We will need to develop various conditions under which the system's operation will be observed. Using our PSAT software we will be able to run our simulations repeatedly using normal and faulted conditions. With the HOMER software, we can model our microgrid and analyze the costs and benefits of several configurations (see Figure C). The various faulted conditions could include:

- Balanced and Unbalanced Load Flow
- Connection and Disconnection of Loads (Figure A)
- Faults in the Sources
- Faults in Loads
- Islanding Conditions

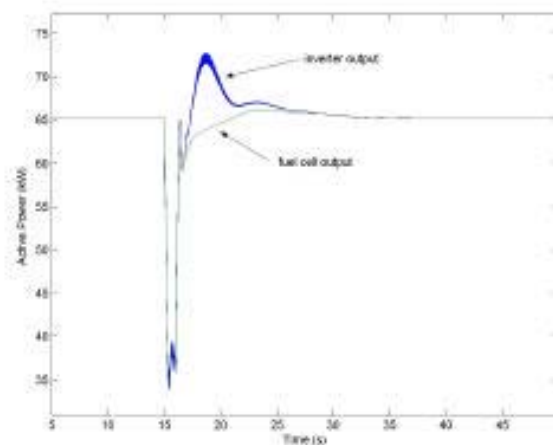

Figure A. Results of a disconnection of a 70 kW active load, followed by its reconnection 1 second later under islanding conditions.

Source: <<http://www.microgrids.eu/micro2000/presentations/6.pdf>>

We will also implement knowledge gained through projects that have been and are currently being performed by other entities and compare their results with the results

that we get from our own testing. HOMER will allow us to enter relevant information in order to perform our cost/benefit analysis of the microgrid system. Integration of distributed energy resources and energy storage capabilities have been covered by other projects (i.e. CERTS Microgrid concept) and this information will be used to calculate associated costs and benefits as it relates to our design. When more information becomes available through our external advisors, we will adjust our approach accordingly including alternative solutions.

Team SMART has collective experience in Network Analysis, Energy Conversion, and Power Systems Analysis courses. Specific topics from these courses include:

- Kirchoff's Voltage and Current Laws
- One-Line Diagrams
- Distributed Generation
- Three-Phase Systems
- Renewable Energy Resources

In addition to the above topics, the Team will seek to gain more knowledge in power systems analysis and simulation tools and power electronics. These courses will allow us to take a holistic approach to power systems while still being able to use simple concepts to perform specific calculations.

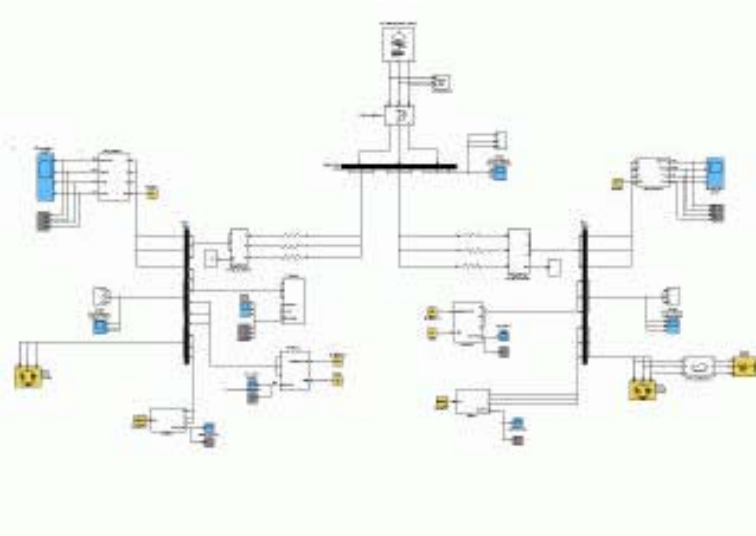

Figure B. Example of a balanced operation model developed in a MATLAB/Simulink environment. Source: <<http://www.microgrids.eu/micro2000/presentations/6.pdf>>

Because the main objective of our project is to model, simulate, and analyze a microgrid system, we will need to explain the rationale for using these software tools, highlighting their functions and how they will assist us in completing our short-term and long-term goals.

*Hybrid Optimization Model for Electric Renewables (HOMER)*

HOMER was created by the National Renewable Energy Laboratory (NREL) in 1993. According to the HOMER Energy website, HOMER is a computer model that simplifies the task of evaluating design options for both off-grid and grid-connected power systems for remote, stand-alone and distributed generation (DG) applications. This type of evaluation will prove useful in satisfying our proof-of-concept design requirement. During disturbances the generation and corresponding loads can separate from the distribution system to isolate the microgrid's load from the disturbance, also known as going off-grid (Lasseter). HOMER will also assist our cost/benefit analysis through its optimization and sensitivity analysis algorithms that will allow us to evaluate the economic and technical feasibility of a large number of technology options and to account for uncertainty in technology costs, energy resource availability, and other variables. This is seen in Figure C.

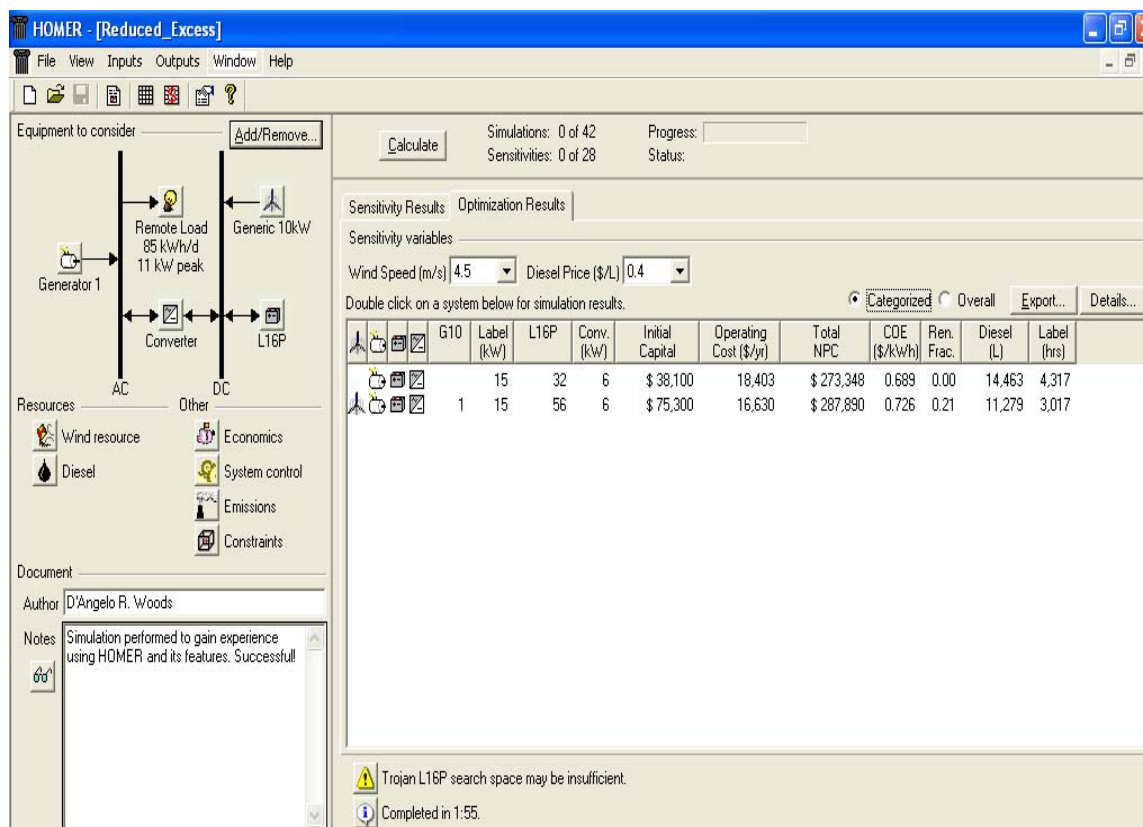

Figure C. Preliminary Schematic using HOMER. This particular simulation was able to choose from among several options the most cost-feasible combination of components and displays the optimal choices. Note the lower overall price is associated with the system that does not include a wind turbine.

Each team member will download HOMER and perform sample simulations in order to become acquainted with the software.

### SimPowerSystemsAnalysis 5.2

The MathWorks, creator of the MATLAB and Simulink environments, defines the SimPowerSystems software as a modern design tool that allows scientists and engineers to rapidly and easily build models that simulate power systems. The toolbox will work with our MATLAB/Simulink software as an add-on to model electrical, mechanical, and control systems which will be useful in modeling our microgrid and evaluating its operation under normal and faulted loads.

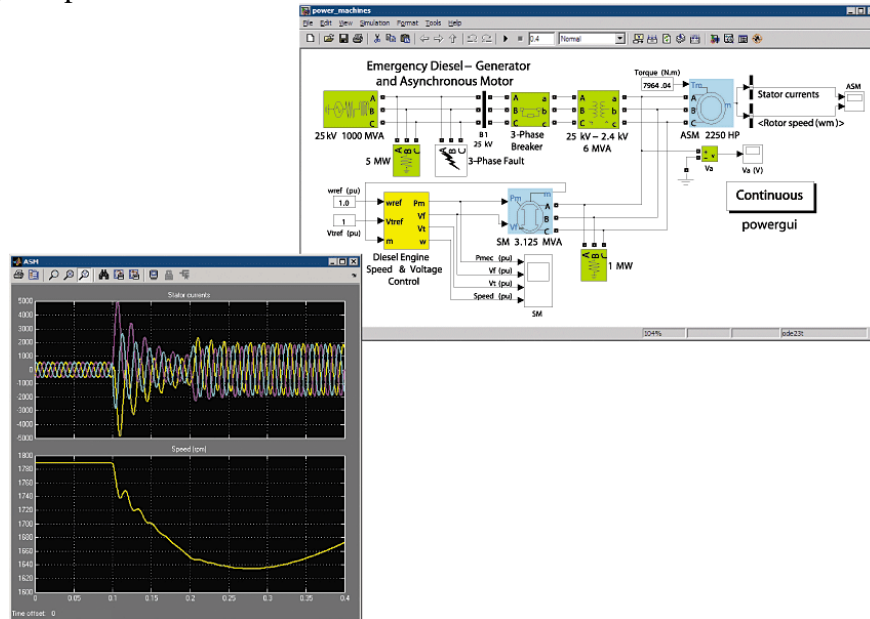

Figure D. SimPowerSystems Model of an Asynchronous motor and Diesel-generator Uninterruptible Power Supply (UPS)

### *MATLAB/SimuLink*

“MATLAB® is a high-level language and interactive environment that enables you to perform computationally intensive tasks faster than with traditional programming languages such as C, C++, and Fortran,” according to its product page on The MathWorks website. The MATLAB environment presents us with a programming atmosphere that is conducive to generating code that is compatible and that will control our Simulink models. Simulink allows users to model, simulate, and analyze dynamic systems and from it we can build our model either from scratch or from existing models. The MathWorks also mentions that we can use the sensor blocks in SimPowerSystems to measure current and voltage in our power network, and then pass these signals into standard Simulink blocks. Source blocks enable Simulink signals to assign values to the electrical variables current and voltage. Sensor and source blocks allow us to connect a control algorithm developed in Simulink to a SimPowerSystems network. All of our team members have experience generating code and plots using MATLAB and thus time will be saved when performing any relevant tasks with the software.

## *Power Systems Analysis Toolbox (PSAT)*

PSAT was developed by Federico Milano as an electric power system analysis and control toolbox that is compatible with MATLAB. The use of PSAT is necessary especially for our faulted conditions. Fault analysis, harmonic analysis, and protection analysis tools are currently unavailable from MATLAB packages and toolboxes. PSAT will allow us to perform optimal power flow analysis on our system and serve as a useful toolbox to use with our Simulink environment for conditional analyses. Because our MATLAB package does not contain tools for fault analysis, PSAT will serve us well when simulating under faulted conditions.

### **Project Management**

#### *Timeline and Milestones*

<b>Assignment</b>	<b>Deadline</b>
<b>Proposal Presentations</b>	November 13, 2009
<b>Written Proposals: Version II</b>	November 18, 2009
<b>Full Design Proposals</b>	November 20, 2009
<b>Final Proposals</b>	December 2, 2009
<b>Team Evaluations</b>	December 2, 2009
<b>Peer Evaluations</b>	December 2, 2009
<b>Team Binder</b>	December 2, 2009
<b>Evaluation/Selection of Design</b>	December 14, 2009
<b>Simulation, Testing, and Re-Evaluation</b>	January 18, 2010
<b>Final Design</b>	February 15, 2010

#### *Task Assignments*

Because we believe that every member of this team is a leader, we have not assigned a team leader. However, to organize and optimize the Team's efforts and activities, each team member was assigned roles in accordance with their special skills and abilities. These roles are as follows:

- Christina Cheek will develop and prepare our mathematical models for simulations.
- Mulugeta Damamo will perform our carbon emissions analysis.
- D'Angelo Woods will obtain information from SDG&E for component specifications and to establish feeder peak load baseline.
- All team members will conduct research of microgrid concept and use simulation tools to acquire data.

### *Deliverables*

- Microgrid Model
- Report on Microgrid Operation Under Normal/Faulted Conditions
- Microsoft Excel Spreadsheet of Cost/Benefit Analysis
- Emissions Analysis Report

### *Ethics*

As stated in our Team contract, we will adhere to the ethical standards set forth by the Institute of Electrical and Electronic Engineers, which are as follows:

1. to accept responsibility in making decisions consistent with the safety, health and welfare of the public and the Howard University community, and to disclose promptly factors that might endanger the Howard University community, public, or environment ;
2. to avoid real or perceived conflicts of interest whenever possible, and to disclose them to affected parties when they do exist;
3. to be honest and realistic in stating claims or estimates based on available data;
4. to reject bribery in all its forms;
5. to improve the understanding of technology, its appropriate application, and potential consequences;
6. to maintain and improve our technical competence and to undertake technological tasks for our internal and external advisors only if qualified by training or experience, or after full disclosure of pertinent limitations;
7. to seek, accept, and offer honest criticism of technical work, to acknowledge and correct errors, and to credit properly the contributions of others;
8. to treat fairly all persons regardless of such factors as race, religion, gender, disability, age, or national origin;
9. to avoid injuring others, their property, reputation, or employment by false or malicious action;
10. to assist colleagues and fellow students in their professional development and to support them in following this code of ethics.

In addition to these standards, each team member shall maintain a positive attitude towards his/her teammates, external and internal advisors, classmates, company sponsors, and administrators.

## Budget

Our tentative budget for this project is presented below:

Item	Description	Cost	Total Cost
<b>MATLAB/Simulink Student Version</b>	MATLAB is a numerical computing environment and fourth generation programming language. Developed by The MathWorks, MATLAB allows matrix manipulation, plotting of functions and data, implementation of algorithms, creation of user interfaces, and interfacing with programs in other languages (MATLAB)	\$99.00	
<b>SimPowerSystems Toolbox</b>	SimPowerSystems™ extends Simulink® with tools for modeling and simulating the generation, transmission, distribution, and consumption of electrical power. It provides models of many components used in these systems, including three-phase machines, electric drives, and libraries of application-specific models such as Flexible AC Transmission Systems (FACTS) and wind-power generation.(SimPowerSystems 5.2)	\$59.00 (add-on product)	
<b>Hybrid Optimization Model for Electric Renewables (HOMER)</b>	HOMER is a computer model that simplifies the task of evaluating design options for both off-grid and grid-connected power systems for remote, stand-alone and distributed generation (DG) applications. HOMER's optimization and sensitivity analysis algorithms allow the user to evaluate the economic and technical feasibility of a large number of technology options and to account for uncertainty in technology costs, energy resource availability, and other variables	\$0.00	
<b>Power Systems Analysis Toolbox (PSAT)</b>	The Power System Analysis Toolbox (PSAT) is a MATLAB toolbox for electric power system analysis and simulation. The main features of PSAT include: Power Flow; Continuation Power Flow; Optimal Power Flow; Small Signal Stability Analysis; Time Domain Simulation; Phasor Measurement Unit (PMU) Placement; Complete Graphical User Interface; User Defined Models; FACTS Models; Wind Turbine Models	\$0.00	

<b>Miscellaneous Expenses</b>	Funds that may be used to cover the costs of miscellaneous items, etc.	\$200.00	\$358.00
-------------------------------	--	----------	----------

In addition to these products, the Team will also need to acquire a computer workstation on which to operate this software. This workstation will be either one offered by the College of Engineering or that of one of the Team members at no cost to the Team.

### **Conclusion**

To recapitulate, the need for the revamp of the nation's energy infrastructure has never been so evident. With the emergence of renewable energy generators in homes has become a dire need for a system such as the microgrid to serve as an intelligent interface between individually distributed generators and utility companies. Prior to the complete implementation of the microgrid, it must be proven that the system will operate effectively under both normal and faulted conditions while being cost-effective for both the utility company as well as its customers. The benefit of the project is that the microgrid's advantages and areas for improvement will be determined prior to full implementation, saving time and money for San Diego Gas & Electric and its customers.

As stated before, the Team plans on utilizing MATLAB, HOMER, and PSAT for simulating the power system in normal and faulted conditions. The simulations of faulted conditions should include load problems, islanding issues, and faults in sources. This approach will be refined as more information about the Team's responsibilities is revealed.

The cost of the project should be no more than \$400, including necessary software and other needs. By December 2009, the Team will have developed both the Implementation and Evaluation Plans for the project. The final product will be completed and evaluated by March 2010.



## References

- CERTS. CERTS Microgrid Test Bed at American Electric Power. Consortium for Electric Reliability Technology Solutions (CERTS).  
<<http://certs.lbl.gov/certs-derkey-mgtb.html>>. 1 November 2009.
- EPRI. Micro Grid Energy Storage Demonstration. *CEC/DOE Energy Storage Collaboration*.  
<<http://energystoragedemo.epri.com/cec/microgrid/microgrid.asp>>.  
1 November 2009.
- Kim, Charles, Ph.D. Senior Design Class 2008-2009.  
EECE401 Senior Design I/EECE404 Senior Design II.  
<[http://www.hirstbrook.com/SD0809/DFL\\_PROP.pdf](http://www.hirstbrook.com/SD0809/DFL_PROP.pdf)>. 1 November 2009.
- Mathworks, The. SimPowerSystems 5.2. 1994-2009.  
<<http://www.mathworks.com/products/simpower/>>. 3 November 2009.
- Mathworks, The.  
<<http://www.mathworks.com/access/helpdesk/help/toolbox/physmod/powersys/ug/f10-51564.html> 8 November 2009>. 3 November 2009.
- MATLAB. 2 November 2009. <http://en.wikipedia.org/wiki/MATLAB>.  
3 November 2009.
- Milano, Frederico. PSAT. <http://www.power.uwaterloo.ca/~fmilano/psat.htm>.  
3 November 2009.
- NREL. HOMER. <<https://analysis.nrel.gov/homer/>>. 3 November 2009.
- San Diego Gas & Electric. Smart Grid. *San Diego Gas and Electric Company*.  
<<http://www.sdge.com/smartgrid/>>. 1 November 2009.
- Lilenthal, Dr. P. The HOMER® Micropower Optimization Model. January 2005.  
<<http://www.nrel.gov/docs/fy05osti/37606.pdf>>. 8 November 2009.

## Attachments

The following information will be used to assist in the carbon emissions analysis of the microgrid:

1) April 22, 2009 Mike Chrisman, Chair and Members California Ocean ...  
File Format: PDF/Adobe Acrobat - Quick View  
Calculate **annual CO2** emission rate for reuse, non-potable source: ... **SDG&E**  
assigns a **CO2** emission rate of 915 lb per MW-hr (or 0.915 lb per kWh) for ...  
[www.opc.ca.gov/.../RKII%20Desal%20Letter%20to%20OPC.Final.pdf](http://www.opc.ca.gov/.../RKII%20Desal%20Letter%20to%20OPC.Final.pdf)

2) <http://www.otherpower.com/windbasics1.html>

The statistics used to calculate the distribution of wind speeds are complicated, but the results are easy to understand. In most locations worldwide, the distribution of wind speeds keeps fairly close to a Weibull or (simplified) Rayleigh distribution of wind speeds, shown below. There are non-Rayleigh locations where the curve takes on other shapes, but these are relatively rare. The distribution shown here is relatively common.

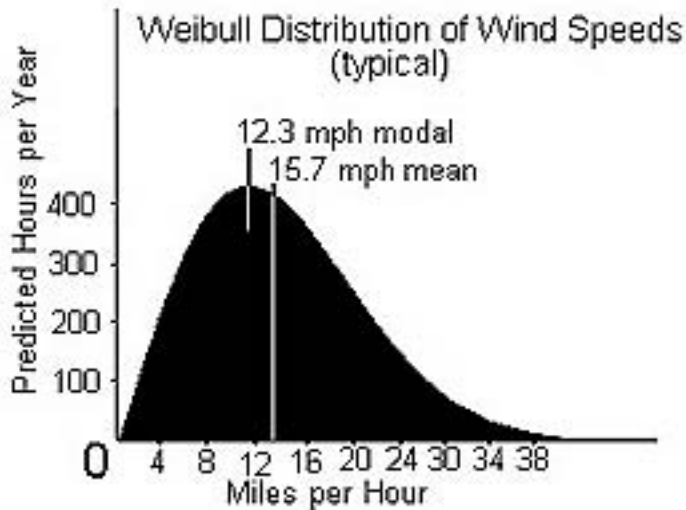

In the chart, the horizontal axis shows wind speed, and the vertical axis the probability (which can be condensed down to the predicted number of hours per year) that the wind is blowing at that speed. The area under the graph is always equal to one, because the probability that the wind is either blowing or not blowing is always 100%.

If we use a 10-foot (3.048 m) diameter rotor for a 7.30 m<sup>2</sup> swept area in a 10 mph wind, we get:

Power available (Watts)

$$= \frac{1}{2} * 1.23 * 7.30 * 4.4704^3$$

\*\* =

**401 Watts**

3)

[http://www.awea.org/faq/wwt\\_basics.html](http://www.awea.org/faq/wwt_basics.html)

Wind turbines vary in size. This chart depicts a variety of historical turbine sizes and the amount of electricity they are each capable of generating (the turbine's capacity, or power rating).

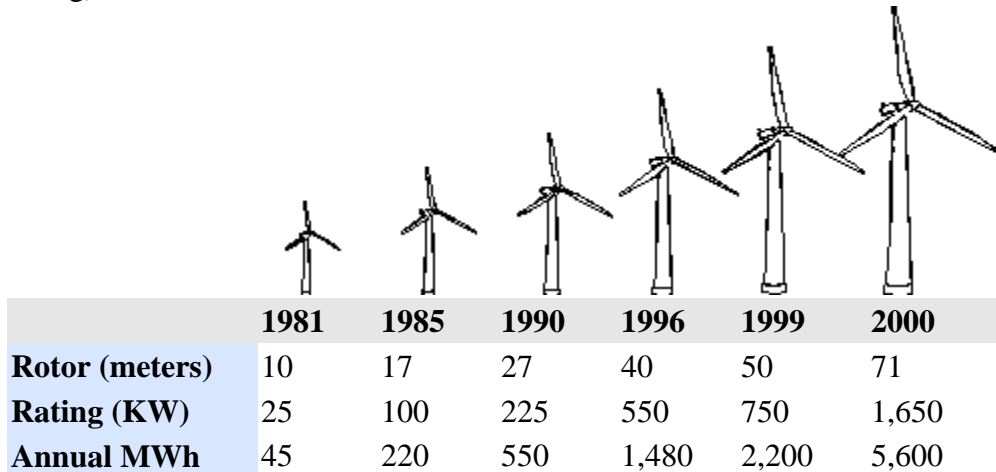

The electricity generated by a utility-scale wind turbine is normally collected and fed into utility power lines, where it is mixed with electricity from other power plants and delivered to utility customers. Today (August 2005), turbines with capacities as large as 5,000 kW (5 MW) are being tested.

4) From source 1,2 and 3

We can calculate how much CO<sub>2</sub> is reduced by our project

From (3): using a 5 MW wind turbine,

From (2): average wind below 12.3 mph for 400hrs a year

We can generate:

Energy = P\*t = 5MW \* 400hrs = 2000MWh annually

So we can reduce:

From (1) and (4):

915 lb per MWh \* 2000 MWh = 1830000 lb of CO<sub>2</sub> per year from a single wind turbine

One wind turbine needs 0.008178 sq. mile to plant

If we use 1% of SDG&E covered area (4100 sq. mile) to implement wind turbines, we can plant 5013 wind turbines (source: Scientific American , Nov. 2009)

4100\*.01= 41 sq. mile we can plant 5013 wind turbines

So we can generate:

5013\*2000MWh = 10026 GWh

So using 1% of a covered area by SDG&E, we can reduce

915 lb per MWh \* 10026000 MWh = 9.17379 trillion lb. per year from SDG&E area; which is good for SDG&E and its customers.