

Design Project Proposal

EECE 401 Senior Design I
Department of Electrical and Computer Engineering
Howard University

MEMORANDUM

November 24, 2009

TO: Dr. Charles Kim
Instructor

FROM: Itotoh Akhigbe
Kimario Inniss
Lloyd Eley

SUBJECT: Design Project Proposal Submission

Enclosed is our group's design project proposal, Demand Response. This proposal is submitted for partial fulfillment of the Senior Design requirement outlining the plan for the project pursuit through the problem formulation with functional requirement, alternative solution generation with electrical and computer engineering approaches, project management and milestones, and task assignments and deliverables. We understand this proposal, in written report as attached and oral presentation upon scheduled, would undergo a rigorous Proposal Review Panel assessment, and we are willing to accept recommendations from the Panel Review and modify and resubmit for final approval.

Design Project Proposal

Demand Response

Submitted by

**Itotoh Akhigbe
Kimario Inniss
Lloyd Eley**

Approved by

Proposal Review Panel Representative:

Name Signature Date

Senior Design I Instructor:

Name Signature Date

Demand Response

1. Introduction

The demand for power in the world today is increasing rapidly for residential, commercial, and industrial uses. This has caused a serious concern for the power industries, and after numerous research studies, the power industry developed a software system that was able to persuade electric power customers to reduce their power consumption at a certain time. These systems are called the Demand Response Systems.

Demand Response Systems are programs that manage the electricity consumptions by customers in relation with production of electricity. This is done by encouraging customers to reduce their electricity consumption at certain critical time (peak time). To encourage customers to reduce their power consumption, the demand response system either sets a standard peak consumption and any customer who consumes more than the standard peak is a differential rate or the utility company develops a program that offer customers incentives for reducing their energy consumption during certain time periods.

The Howard University Demand Response Team, as the name implies, is responsible for developing a demand response system that will reduce the peak power consumption of Tacoma Power customers concentrating on the climate of the Northwestern part of the United States of America and its impact on energy consumption.

2. Problem Definition

The project group task with building a system that comprises of a software package and a small scale demo. The software package will consist of peak power consumption limits for certain conditions or for certain time periods and will be based on analysis of electricity consumption by Tacoma Power residences from past years. The Tacoma Demand Response team will build a system that will encourage Tacoma Power's customers to reduce their peak electricity consumption. Also, this system will be able to reach certain requirements like; reduce the peak electricity consumption by the Customers by 10%, fit into the present Tacoma network, abide by the Federal and States Rules and Regulations like the Federal Energy Regulatory Commission (FERC) which requires a detailed platform of how the demand response system will impact Tacoma Power's energy consumption, and concentrate on the climate in the Northwest areas of the United States of America

3. Current Status of Art

Since Demand Response has been introduced, a lot of utility companies have implemented the program into their power system. Most of this implementation has been classified into two types, real time pricing and time of use pricing.

The real time pricing program is based on charging customers rates based on the time they consume their electricity. This particular program works well because utility companies are able to have a demand response system that charges customers a price quota corresponding to their particular power usage during a certain time period. The system price quota increases as the power consumption increases (between 200MW/hr and 300MW/hr will cost \$200 and between 500MW/hr and 500MW/hr will cost \$800) and encourages customers participating in the program, to reduce their energy consumption during that time period. The peak power consumption will also be reduced or shifted to a different time and the purpose of the demand response system is accomplished. One company that uses this type of demand response program is Duke Power. Duke's demand response program charges real-time prices to about 100

customers with about 1000 MW of load. Duke has observed reductions of 200 MW in these customers' load in response to hourly prices above 25 cents per kilowatt-hour.

Another way to apply a demand response system is by using the time of use pricing. This type of pricing involves analyzing past peak power consumption time periods and then using the data to establish prices. This Demand Response program can be implemented by researching past time periods where the utility company experienced peak power consumption and charging customers differential rates during this time. For example, if the peak power consumption was between January and February for the past five years, it is likely that it will be the same the next year. Based off of this finding, the utility company would charge a higher rate during this time particular time period. This would motivate customers to be conscious of the amount of power they are consuming during this time period and reduce their energy consumption. In Oregon, time-of- use pricing options have been offered to residential customers of Portland General Electric and PacifiCorp since March 1, 2002. So far about 2800 customers have signed up, and early measures of satisfaction are encouraging, but data are not yet available on any changes in their energy use patterns.

4. Engineering Approach (including alternative solution)

The Demand Response team has come up with two approaches for Tacoma to implement a demand response program for their customers. The first approach will be the major approach and the second approach will be the alternative approach in event the first approach fails.

MAJOR APPROACH

Below is the algorithm for the first approach (Figure 1):

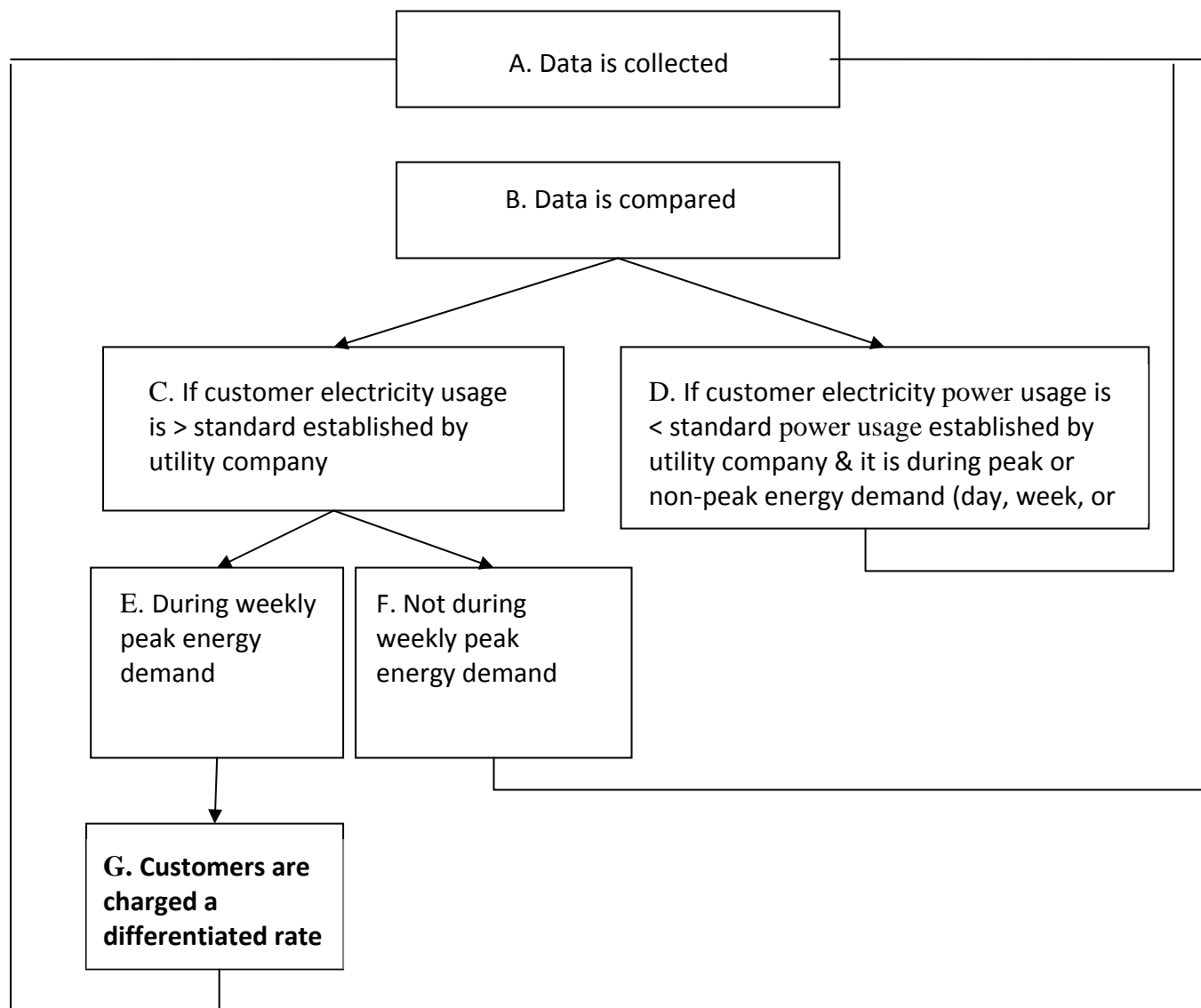

Figure 1: Algorithm

From the algorithm there are seven steps to the demand response system that we are going to build. Listed below is a detailed outline of each step:

Step A: The power consumption data will be collected. For a large scale utility company like Tacoma Power, we will advise them to start using a real time data system. The best way to receive accurate real time data is using a smart meter. The smart meter is a meter that reads real time data and communicates real time data between the utility company and consumer (Figure 2).

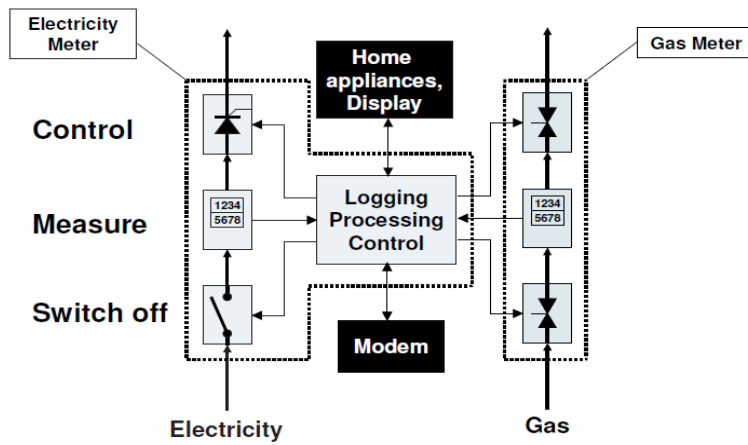

Figure 2: Smart Meter Schematic

For our project which will be on a smaller scale, we will use a load bus; this load bus will contain light bulbs and other small electronics of different watts.

Step B: The data is compared. The data from step A will be sent to a Field Programmable Gate Array (FPGA) Board that has already been programmed with the different threshold power consumption peaks. The first threshold will be a peak power consumption established by the utility company. After this threshold, there will also be different thresholds based on data collected from past Tacoma residential load profiles. These thresholds will be used to determine when to send a warning to customers and when to charge customers a differential rate. An example of the load profiles we will be analyzing can be seen in Figure 3. We will examine past customers' electricity usage and establish different peak time periods based off this data.

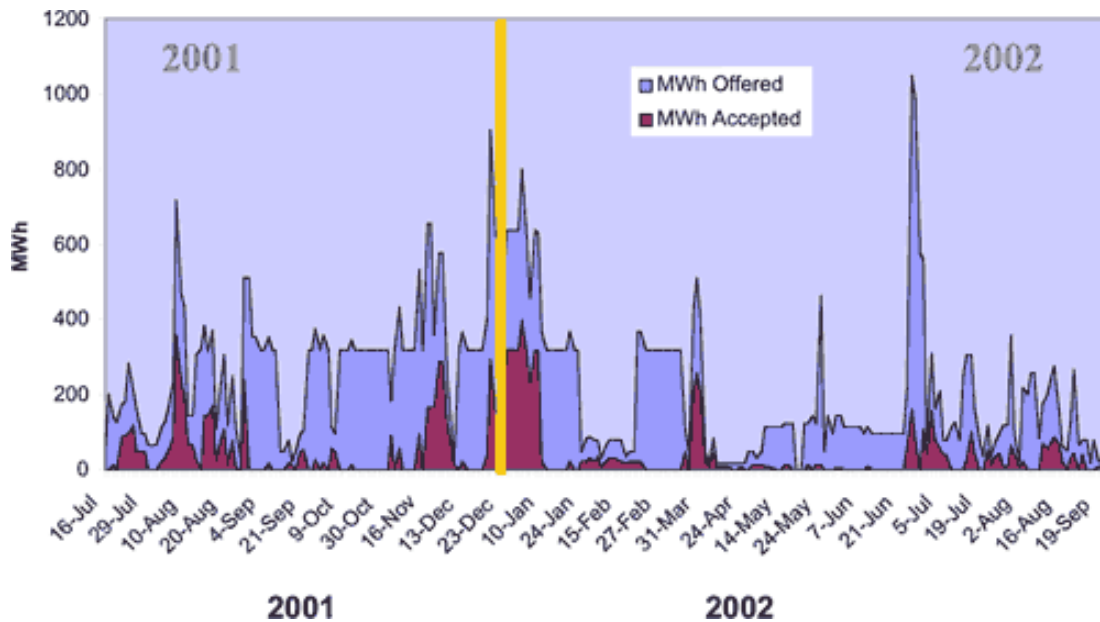

Figure 3: Customer Electricity Usage

This graph shows electric power consumption from 2001 and 2002. From this graph we will set different threshold peak values for each week (Table 1).

Date	Suggested Threshold Values
January 1 st to January 10 th	360MWh
January 11 th to January 23 rd	0.881MWh
January 24 th to February 27 th	45MWh
February 28 th to March 31 st	0.881MWh
April 1 st to April 24 th	225MWh
April 25 th to May 24 th	18MWh
May 25 th to June 21 st	0.881MWh
June 22 nd to July 19 th	180MWh
July 20 th to September 20 th	90MWh
September 21 st to October 9 th	45MWh
October 10 th to October 30 th	0.881MWh
October 31 st to November 16 th	25MWh
November 17 th to December 31 st	360MWh

Table 1: Suggested Threshold Power Peak Values

Since our team plan to reduce the peak power consumption by 10%, we used the graph in figure 3 to calculate a 10% reduction at different time periods. We will then use these values as our suggested thresholds for different time periods throughout the year.

Step C1: The data is compared. If the data is below the standard threshold power peak consumption, then the FPGA board displays a symbol that says the customer is using below the standard threshold peak power.

Step C2: The data is compared. If the data compared is above the standard threshold peak power, but below the threshold to charge customers a differential rate, it will display a symbol on the FPGA Board to warn the customer he/she is above the standard power peak limit and then the data will be compared through another comparison check

Step D1: Once the customer receives a warning, then the data is compared again. Depending on the time period, if the data compared is greater than the corresponding threshold peak power for charging customers a differential rate, then the FPGA board will display the customer he/she is being charged a differential rate.

Step D2: Once the customer receives a warning, then the data is compared again. Depending on the time period, if the data compared is still below the corresponding threshold peak power for charging customers a different rate, then the FPGA board will continue to display the warning symbol. If the power consumption is below the warning threshold, then the FPGA will display a symbol that states the customer is using below the standard threshold peak power.

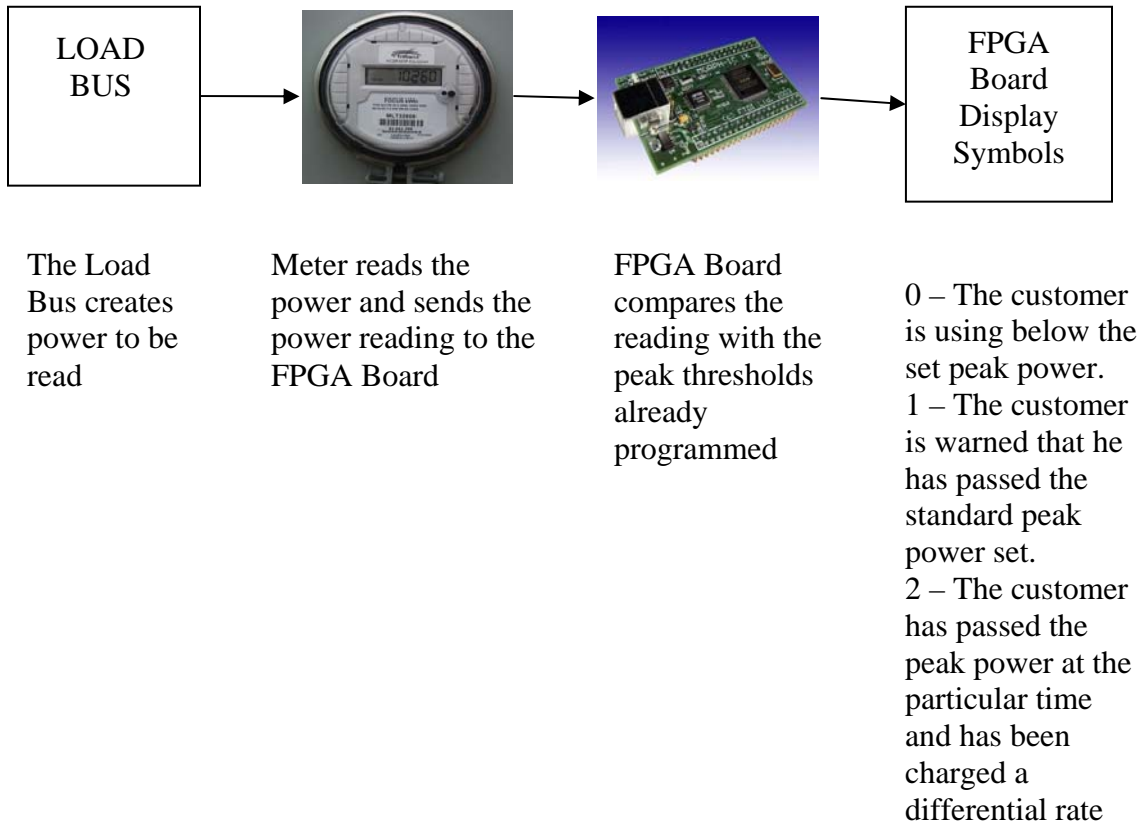

Figure 4: Final Main Approach Set Up

ALTERNATIVE APPROACH

The Demand Response Team also plans to develop an alternative approach. This plan is called the Payback (Incentive) Approach and involves the team analyzing past power consumption data and advising customers that, if they can reduce their peak power consumption by a certain percentage compared to their past peak power consumption, they will receive an incentive (Figure 5).

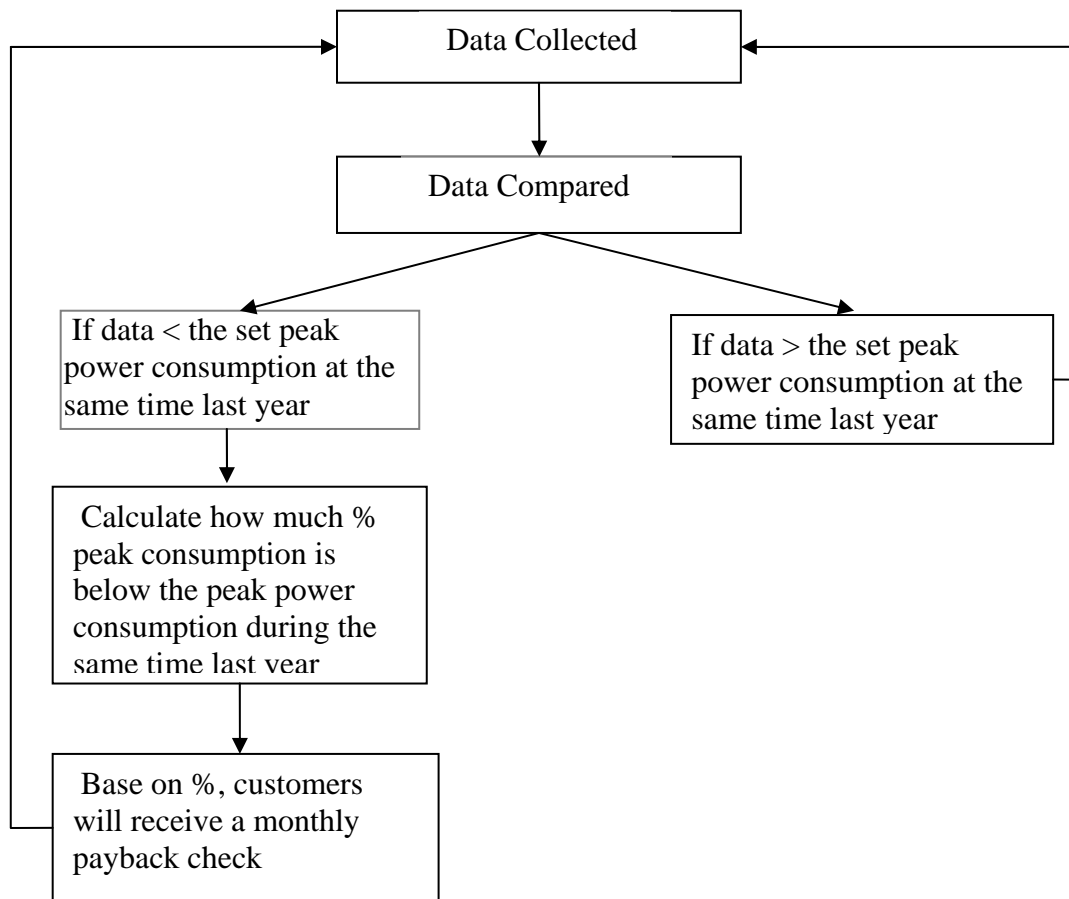

Figure 5: Algorithm of the Alternate Approach

The above algorithm shows how we plan on accomplishing the payback demand response system. Below is a detailed outline of each step represented in the algorithm:

Step A: The power consumption data is collected. For a large scale utility company like Tacoma Power, we advise them to implement a real time data system using the smart meter.

As mentioned in the previous section, a smart meter is a meter that reads real time data and communicates data between the utility company and consumer.

Step B: The data is compared. The data from step A will be sent to a FPGA Board that has been programmed to different threshold power consumption peaks at different time periods of the year (See Figure 6).

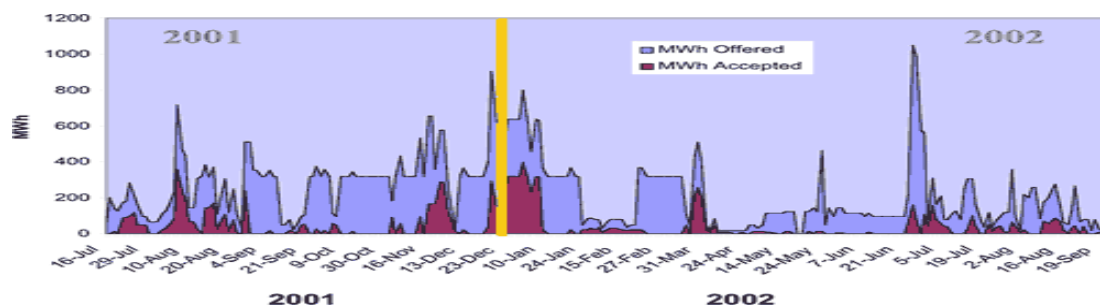

Figure 6: Customer Electricity Usage

This graph shows the usage of electric power from 2001 and 2002. From this graph we can set different threshold peak values for each week.

Date	Suggested Threshold Values
January 1 st to January 10 th	360MWh
January 11 th to January 23 rd	0.881MWh
January 24 th to February 27 th	45MWh
February 28 th to March 31 st	0.881MWh
April 1 st to April 24 th	225MWh
April 25 th to May 24 th	18MWh
May 25 th to June 21 st	0.881MWh
June 22 nd to July 19 th	180MWh
July 20 th to September 20 th	90MWh
September 21 st to October 9 th	45MWh
October 10 th to October 30 th	0.881MWh
October 31 st to November 16 th	25MWh
November 17 th to December 31 st	360MWh

Table 2: Assumed threshold Power Peak Values

Since our aim is to reduce the peak power consumption by 10%, from the graph we calculated a 10% reduction in each of the peak consumption at different times (Table 2).

Step C1: At a particular, if the data is below the corresponding peak power consumption, then the algorithm proceeds to step D.

Step C2: At a particular time if the data is more than the peak power, then the FPGA displays a 0 to alert the customer that their power consumption is great than their peak power consumption for the same time period last year

Step D: If the data is lower than the set peak power at that particular time, then the system calculates the reduction percentage in response to the peak power from last year and displays the percent amount on the FPGA board ([Percent reduction calculation – peak consumption power being used currently/ past peak power consumption during the same time period]*100)

Step E: Depending on the percentage reduction, there will be a paycheck return to the customer (Table 3).

Percent Reduction	Paycheck Amount
Below 10%	3% of your total electricity bill will be sent back to the customer
11%-20%	5% of your total electricity bill will be sent back to the customer
21% - 30%	10% of your total electricity bill will be sent back to customer.
Above 30%	20% of your total electricity bill will be sent back to the customer

Table 3: Paycheck Amount in Response to Customer's Percent Reduction

We will evaluate both of our solutions by setting up a small scale demo consisting of an FPGA, small appliances/electronics, and an electricity meter. The FPGA will be preprogrammed with threshold values and act as an alarm system to alert the consumer when they are nearing the threshold and when they are being charged a differential rate. To increase the electricity flowing through the power system we will add small appliances/electronics. The meter will monitor the electricity consumption and communicate directly with the FPGA board to alert the consumer. If the customer is charged a differential rate, then this information will be stored and sent to the utility company. Our small scale demo will be an automated demand response system, communicating real time data to both the consumer and the utility company.

5. Tasks and Deliverables

Tasks	Deadline
Research current demand response system and decide which one will be the most beneficial to Tacoma Power	November 1, 2009
Develop a proposal to be implemented next semester	November 4, 2009,
Develop a clear plan of action for implementing the Demand Response System	November 25, 2009
Schedule teleconference dates with our external advisors (Tacoma Power) for the entire semester	By January 6, 2010
Develop and submit the design of the demand response framework to be implemented	January 17, 2010
Begin implementing the demand response system	January 18, 2010
Complete first working demo of our demand response system	February 14, 2010
Complete final demo and report	March 1, 2010

As with any project development lifecycle, there are major steps the team will confront. These are project initiation, preliminary engineering, planning, construction, and deliverance of a demand response program. The Demand Response team will be managing all of the systems and controls modules. The first module focused on researching current demand response programs. The first deliverables for the team included current demand response programs and strategies the team could take in order to implement a demand response program to Tacoma Power's current power system. The team responsibilities comprise of the demand response architecture and the handling of a high power electrical system when Tacoma experience peak energy demands. The demand response architecture will require control system definition and strategy development for its implementation. Thus, the endeavor will have particular emphasis on power system design using math-based design tools.

Deliverables for the second module included the submission of a demand response report and a demand response strategy presentation. The Howard University Tacoma Power team's proposal, Report 1: Demand Response Proposal was defined in the November 3rd submission. The report contained the selection of a demand response program and the proposal for the team's demand response system. Due at the end of November 2009, Report 2: Demand Response Design will outline the finalized demand response system architectural design. The group's presentation, delivered mid November, evaluated how the Demand Response architecture met the objectives of Tacoma Power. Due mid-April 2010, Report 3: Demand Response System Development and Integration, will highlight the complete demand response setup design. We will also submit a small scale demo of

our main demand response program. Due the first week of May 2010, Report 4: Final Design will detail the demand response testing results and resulting control strategy and program design.

6. Project Management

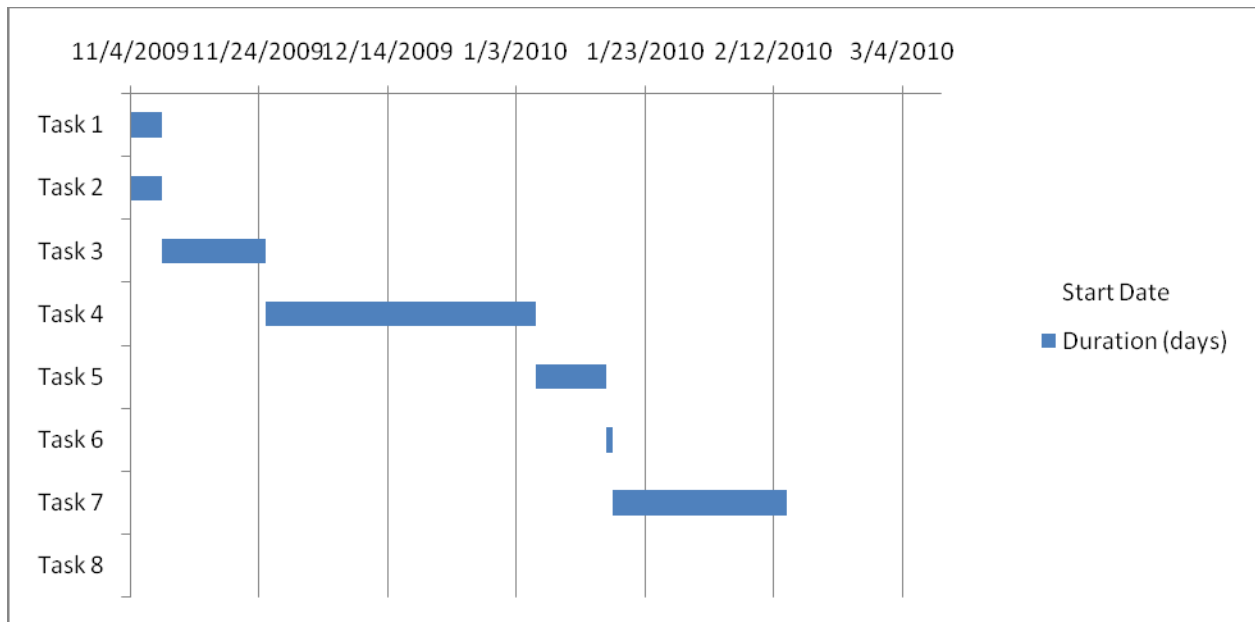

Task 1: Each member of the group was responsible for researching current demand response systems and then we held a meeting and decided which one was the most beneficial to Tacoma Power

Task 2: Each member of the group was responsible for developing a proposal to be implemented next semester and then we held a meeting and decided which two were the most beneficial to Tacoma Power

Task 3: Each member of the group was responsible for developing a clear plan of action for implementing the Demand Response System and then we will hold a meeting and decide which two ideas are the most beneficial to Tacoma Power

Task 4: Marc is responsible for scheduling teleconference dates with our external advisors (Tacoma Power) for the entire semester

Task 5: The entire team will meet and begin implementing the demand response system

Task 6: The entire team will meet, develop, and submit the design of the demand response framework implemented

Task 7: The entire team will complete the final working demo of our demand response system and submit our final report.

7. Cost

The cost of the project will be broken down as such; FPGA Board - \$60.00, Meter - \$140.00, Miscellaneous - \$100.00. The miscellaneous category will include any items that may come up that we did not include in our initial budget. The total estimate price to implement the project including a small scale demo is \$300.

8. Conclusion

The Demand Response team will build a system that will reduce the peak power consumption as mentioned above in our major and alternative approaches. We felt the best demand response programs for Tacoma Power were the differential rate system and the payback return check system. Since Tacoma is located in the northwestern part of the United States, we felt the differential rate system was the best demand response for Tacoma Power. Since the northwestern United States experience cold winters, we knew that our demand response system would have to be able to respond to large energy consumption peaks during this time. Our differential rate system would have the capabilities to reduce customers' energy consumption during the winter, by charging a higher rate to customers who energy consumption was greater than the threshold. We will also lower the threshold value during the winter months when Tacoma experience very high energy consumption, so that more customers are impacted by the charge. This will persuade more customers to reduce their energy consumption during the winter and decrease Tacoma's energy consumption peak. Also, by analyzing past Tacoma Power residential load profiles and identifying when they experience energy consumption peaks (week, month, and season) will enable us to establish our thresholds and make a unique demand response program for Tacoma Power.

9. References

1. <http://www.demandresponseresources.com/>
2. Earle, Robert, Kahn, Edward P., Macan, Edo. "Measuring the Capacity Impacts of Demand Response."
3. Gerwen, Rob van, Jaarsma, Saskia, Wilhite, Rob. "Smart Metering."
4. Sidran, Mark. "Demand Response in Washington State Programs and Issues."

10. Attachment: Final Design Requirement Form